

SLITTING/ SLOTTING/ CUT-OFF SERIES



Video



The Safest Saw

Patented embedding system assures the rigidity of inserts clamping which enhances the tool life and cutting speed, meanwhile realize impressive productivities.

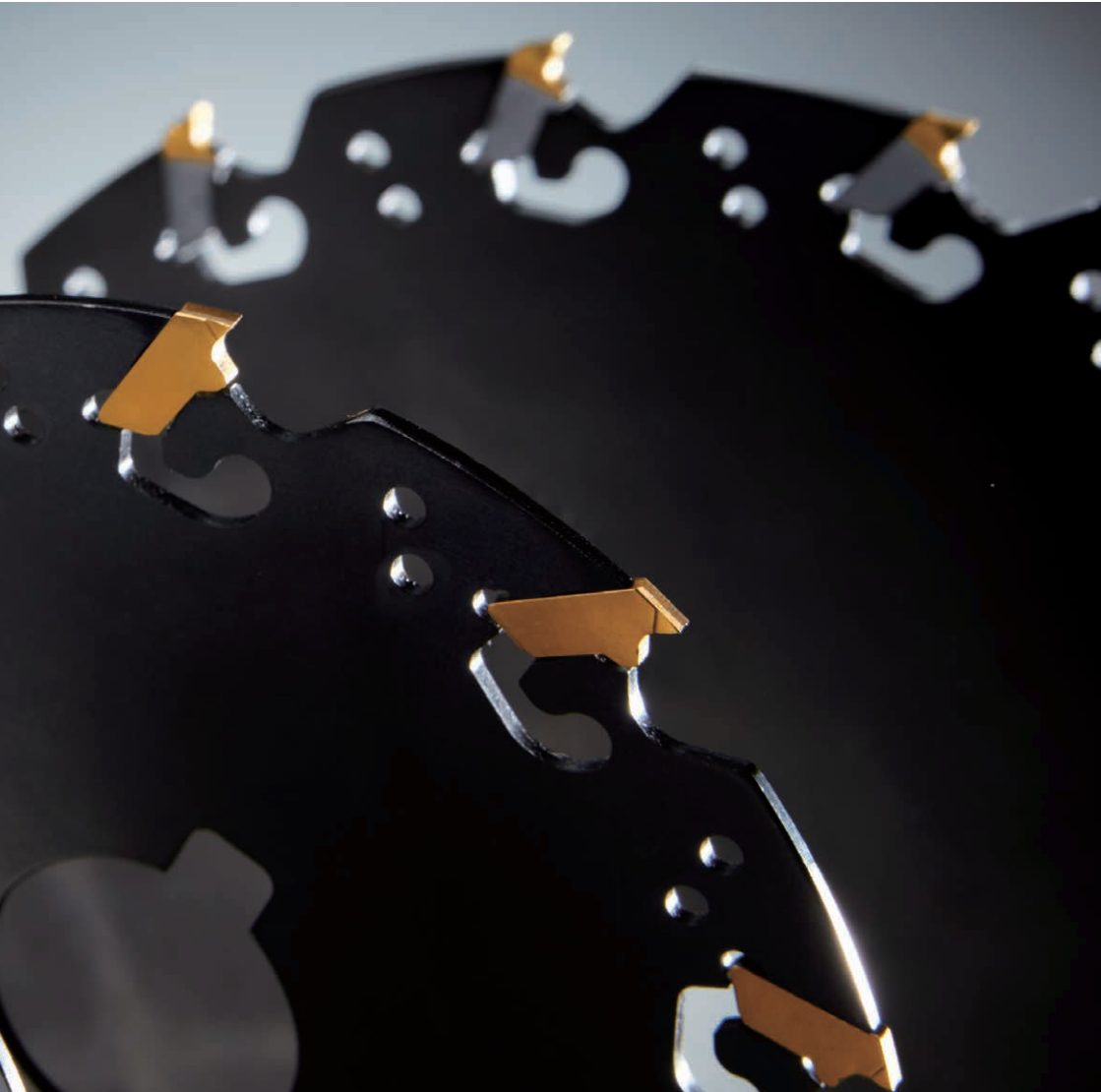

SAW BLADE

PATENTED



Video

Features

Available in
materials



Cost
200~300%
SAVING

Applicable
Machines
Milling machine

Efficiency
300~500%
UP

Durability
300%
UP

SLITTING/SLOTTING/CUT-OFF SERIES

Classification table

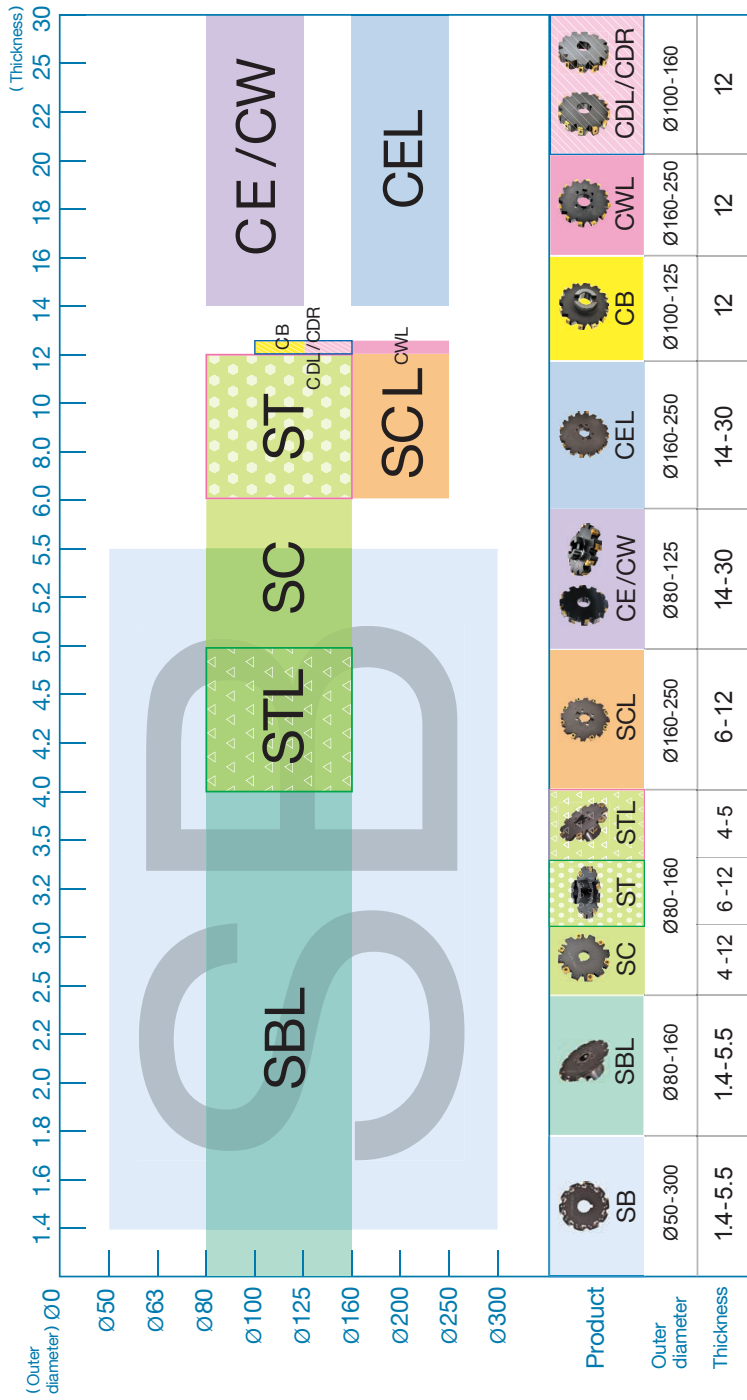

Unit: mm

Traditional vs. New Patent

"Yih Troun" is the first ever in the world which developed this precise locking type saw blade.



1. The screwless indexable insert was TIALN coated and designed with exclusive geometric angle on the cutting edge for producing impressive performance.
2. It increasing the machining (cutting) speed 300% - 500%
3. Cut down the cost of cutting tools



Patent No. : M538848



Patent No. : ZL 2016 2 1300067.8



PCT Priority

Traditional

Solid type saw blade:

1. HSS Saw is only available with low cutting speed, if speed up, the blade will be damaged soon.
2. The carbide brazed saw is welded by high temperature and without coating, it will degrade the body hardness and machining performance.



Multi Functional Saw Blade

1 Same cutter applicable to inserts of :

A. Different materials



B. Different thickness

ex.: 1.75 mm cutter can fit inserts 2.0/2.2/2.5mm

C. Different insert forms

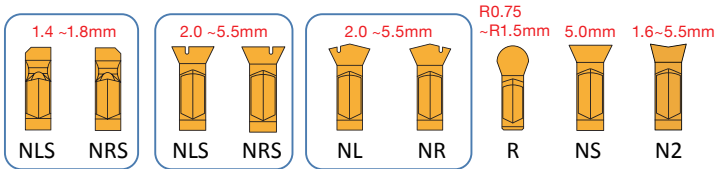

2 Patented embedding system

Strong clamping even in high feed machining



Circular embedding system achieves optimum performance in high speed machining, Max. RPM 17200 rev/min, approved in sweden.

Y.T. Patented Chip Breaking System

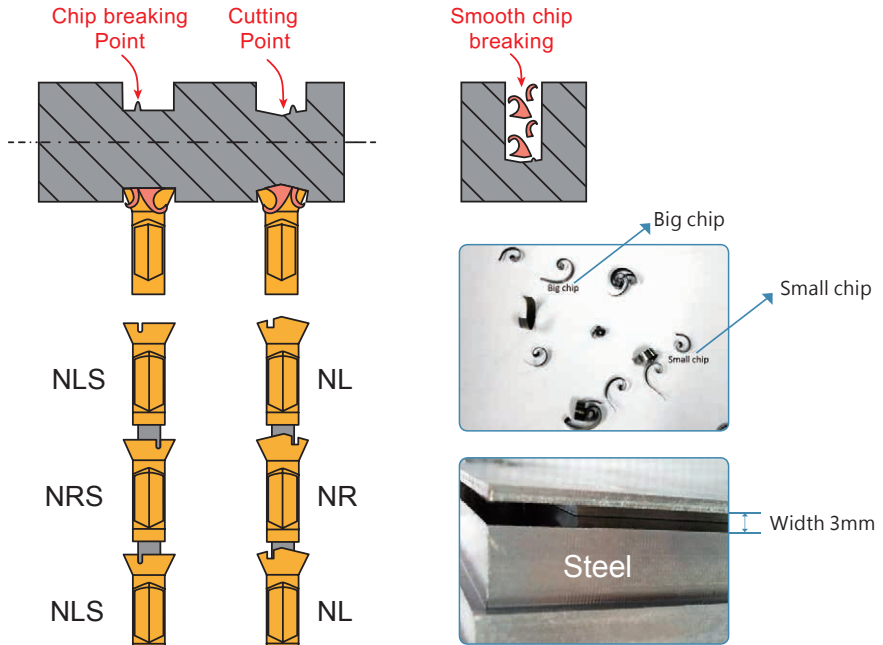

Excellent surface finishing quality and chip evacuation at the live test for machining 20mm deep slots by one pass

Characteristics

- The Insert has unique chip breaker design to break chips into two parts and chips are easily discharged while machining deep grooves and slots.
- It has accurate center positioning design which enables stronger and steady cutter conditions while machining, and lessens vibrations.
- Compare with the saw blades in the market, this design helps in reducing lots of cutting resistances and lower the machining power. It's the best choice for long depth and difficult materials machining.

Defect of other branded self-grip inserts

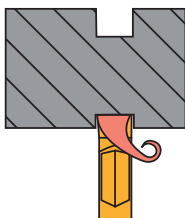

Characteristics

- While in deep grooving, chips often get stuck in the workpiece slot.
- Requires heavy power and generates large resistance in machining.
- As a result, it gives a be poor efficiency and heavy vibrations while large contact machining.

The Solution To Interrupted Cutting:

LNGT Radius Inserts

The radius insert with smooth entering cut provides excellent solution to the interrupted cutting, especially for slitting through the workpiece with holes inside.

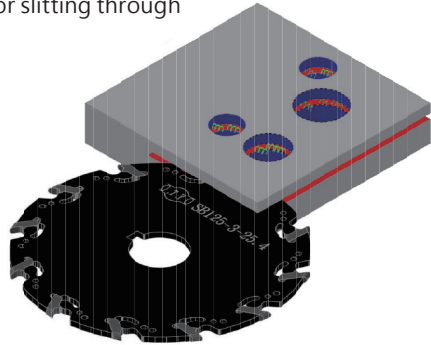

Slitting

Change The Inserts

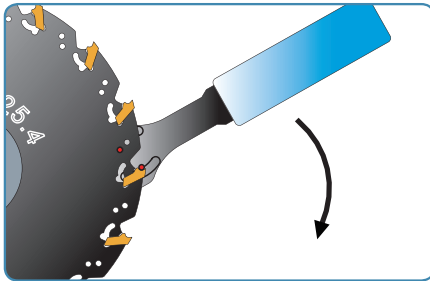

Mount inserts

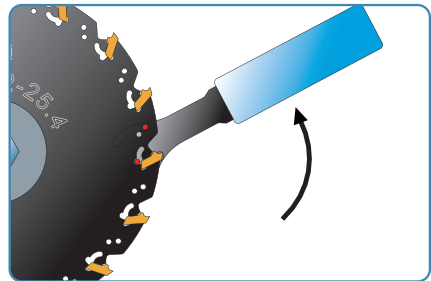

Remove inserts



Video



marker pen (oil-based)

Before mounting inserts, use marker pen (oil-based) to wipe across the concave surface of the insert for helping fit the insert into the blade smoothly.

PRODUCT SPECIFICATIONS

Saw Blades

- Inserts P. 183 - 189
- Cutting Data P. 193 - 195

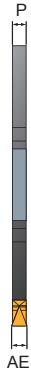
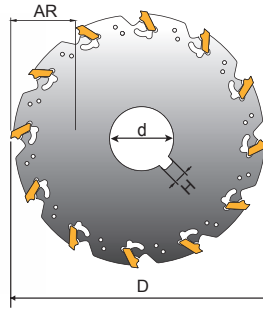

SB

Order Code	Dimensions (mm)							Z	H	KG	MAX. RPM	Insert LNGT	Wrench
	D	AE	AR	P	d	C	B						
SB050-1.4-13	50	1.4	14.5	1.2	13	-	-	4	-	0.07	12000	1414	150.10-30
SB050-1.4-12.7					12.7								
SB063-1.4-16	63		18		16			11000					
SB063-1.4-15.875					15.875								
SB080-1.4-22	80		22.5		22			8000					
SB080-1.4-25.4			19.5		25.4								
SB100-1.4-22	100		32.5		22			6300					
SB100-1.4-25.4			29.5		25.4								
SB100-1.4-27					27								
SB125-1.4-22	125		45		22			5000					
SB125-1.4-25.4					25.4								
SB125-1.4-32					32								

* Wrench for above holders sold separately.

Saw Blades

- Inserts P. 183 - 189
- Cutting Data P. 193 - 195

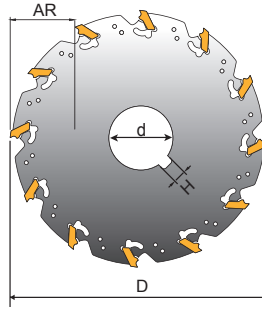

SB

Slitting

Order Code	Dimensions (mm)							Z	H	KG	MAX. RPM	Inserts LNGT	Wrench
	D	AE	AR	P	d	C	B						
SB050-1.6-13	50	1.6	14.5	1.4	13	-	-	4	-	0.08	12000	1616	150.10-30
SB050-1.6-12.7					12.7								
SB063-1.6-16	63	1.6	18	1.4	16	-	-	6	-	0.09	11000	1616	150.10-30
SB063-1.6-15.875					15.875								
SB080-1.6-22	80	1.6	22.5	1.4	22	-	-	8	6	0.09	8000	1616	150.10-30
SB080-1.6-25.4			19.5		25.4				6.35				
SB100-1.6-22	100	1.6	32.5	1.4	22	-	-	10	6	0.14	6300	1616	150.10-30
SB100-1.6-25.4			25.4		6.35								
SB100-1.6-27			27		7								
SB125-1.6-22	125	1.6	45	1.4	22	-	-	12	6	0.21	5000	1616	150.10-30
SB125-1.6-25.4			25.4		6.35								
SB125-1.6-32			32		8								
SB160-1.6-25.4	160	1.6	59.5	1.4	25.4	-	-	16	6.35	0.35	4000	1616	150.10-30
SB160-1.6-32			32		8								
SB160-1.6-40			40		10								

* Wrench for above holders sold separately.

Saw Blades

- Inserts P. 183 - 189
- Cutting Data P. 193 - 195

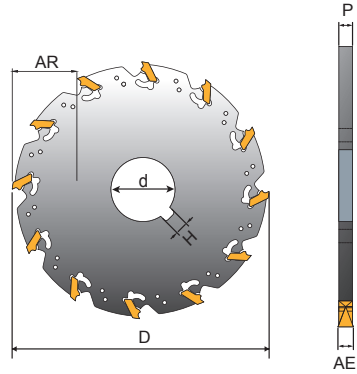

SB

Order Code	Dimensions (mm)							Z	H	KG	MAX. RPM	Inserts LNGT	Wrench
	D	AE	AR	P	d	C	B						
SB050-1.8-13	50	1.8	14.5	1.6	13	-	-	4	-	0.09	12000	1818	150.10-30
SB050-1.8-12.7					12.7								
SB063-1.8-16	63	1.8	18	1.6	16	-	-	6	-	0.10	8000	1818	150.10-30
SB063-1.8-15.875					15.875								
SB080-1.8-22	80	1.8	22.5	1.6	22	-	-	8	6	0.10	8000	1818	150.10-30
SB080-1.8-25.4			19.5		25.4								
SB100-1.8-22	100	1.8	32.5	1.6	22	-	-	10	6	0.15	6300	1818	150.10-30
SB100-1.8-25.4			29.5		25.4				6.35				
SB100-1.8-27			27		7								
SB125-1.8-22	125	1.8	45	1.6	22	-	-	12	6	0.22	5000	1818	150.10-30
SB125-1.8-25.4			42		25.4				6.35				
SB125-1.8-32			39		32				8				
SB160-1.8-25.4	160	1.8	59.5	1.6	25.4	-	-	16	6.35	0.38	4000	1818	150.10-30
SB160-1.8-32			56.5		32				8				
SB160-1.8-40			52		40				10				

* Wrench for above holders sold separately.

Saw Blades

- Inserts P. 183 - 189
- Cutting Data P. 193 - 195

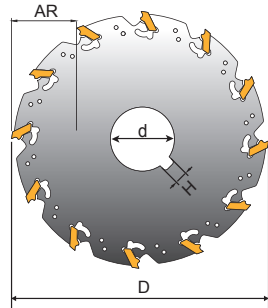

Slitting

SB

Order Code	Dimensions (mm)							Z	H	KG	MAX. RPM	Inserts LNGT	Wrench	
	D	AE	AR	P	d	C	B							
SB050-2-13	50	2.0	14.5	1.75	13	-	-	4	-	0.08	12000	2020 2022 2025	150.10-30	
SB050-2-12.7					12.7			6						
SB063-2-16	63		18		16				8	6	0.10			8000
SB063-2-15.875					15.875									
SB080-2-22	80		22.5		22			6	0.16	6300				
SB080-2-25.4			19.5		25.4						6.35			
SB100-2-22	100		32.5		22			6	0.16	6300				
SB100-2-25.4			2.2		29.5						25.4			6.35
SB100-2-27											2.5			27
SB125-2-22	125		45		22			6	0.24	5000				
SB125-2-25.4			42		25.4						6.35			
SB125-2-32			39		32						8			
SB160-2-25.4	160	59.5	25.4	6	0.39	4000								
SB160-2-32		56.5	32				6.35							
SB160-2-40		52	40				8							

* Wrench for above holders sold separately.

Saw Blades

- Inserts P. 183 - 189
- Cutting Data P. 193 - 195

SB

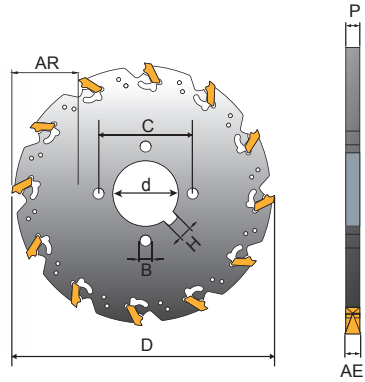

Order Code	Dimensions (mm)							Z	H	KG	MAX. RPM	Inserts LNGT	Wrench
	D	AE	AR	P	d	C	B						
SB200-2-25.4	200	2.0	79.5	1.75	25.4	-	-	20	6.35	0.64	3200	2020	150.10-30
SB200M-2-25.4								26					
SB200-2-32			76.5		32	63	11	20	8				
SB200M-2-32								26					
SB200-2-40			72		40	90	20	10	3200				
SB200M-2-40							26						
SB250-2-25.4	250	2.2	104.5	25.4	-	-	26	6.35	0.96	2600	2025		
SB250M-2-25.4		2.5	101.5				32					63	11
SB250-2-32		97		40	90	26		8					
SB250M-2-32			34										
SB250-2-40		119	32	63	11	26	10						
SB250M-2-40						34							
SB285-2-32	285	3.0	119	32	63	11	28	8	1.12	2300			
SB285M-2-32							40						
SB050-2.5-13	50	2.5	14.5	2.25	13	-	-	4	-	0.1	12000	2525	150.10-30
SB050-2.5-12.7		2.7			12.7								
SB050-2.5-12.7		3.0											

* Wrench for above holders sold separately.

Saw Blades

- Inserts P. 183 - 189
- Cutting Data P. 193 - 195

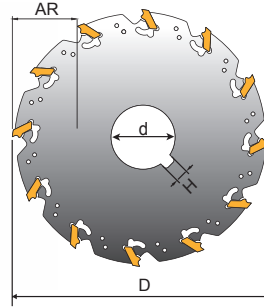

Slitting

SB

Order Code	Dimensions (mm)							Z	H	KG	MAX. RPM	Inserts LNGT	Wrench
	D	AE	AR	P	d	C	B						
SB063-2.5-16	63	2.5	18	2.25	16	-	-	6	-	0.11	11000	2525	150.10-30
SB063-2.5-15.875					15.875								
SB080-2.5-22	80	2.5	22.5	2.25	22	-	-	8	6	0.12	8000	2525	150.10-30
SB080-2.5-25.4			19.5		25.4								
SB100-2.5-22	100	2.5	32.5	2.25	22	-	-	10	6	0.18	6300	2525	150.10-30
SB100-2.5-25.4			29.5		25.4								
SB100-2.5-27					27								
SB125-2.5-22	125	3.0	45	2.25	22	-	-	12	6	0.27	5000	2527	150.10-30
SB125-2.5-25.4			42		25.4								
SB125-2.5-32			39		32								
SB160-2.5-25.4	160	2.5	59.5	2.25	25.4	-	-	16	6.35	0.47	4000	2530	150.10-30
SB160-2.5-32			56.5		32								
SB160-2.5-40			52		40								
SB200-2.5-25.4	200	2.5	79.5	2.25	25.4	-	-	20	6.35	0.73	3200	2530	150.10-30
SB200M-2.5-25.4								26					

* Wrench for above holders sold separately.

Saw Blades

- Inserts P. 183 - 189
- Cutting Data P. 193 - 195

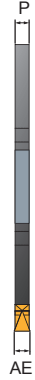
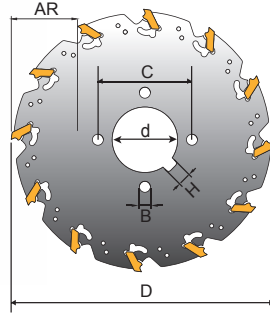

SB

Order Code	Dimensions (mm)							Z	H	KG	MAX. RPM	Inserts LNGT	Wrench							
	D	AE	AR	P	d	C	B													
SB200-2.5-32	200	2.5	76.5	2.25	32	63	11	20	8	0.73	3200	2525	150.10-30							
SB200M-2.5-32								26												
SB200-2.5-40								20	10											
SB200M-2.5-40														26						
SB250-2.5-25.4	250	2.5	104.5	2.25	25.4	-	-	26	6.35	1.12	2600	2525	150.10-30							
SB250M-2.5-25.4								34												
SB250-2.5-32			26		8															
SB250M-2.5-32						34														
SB250-2.5-40			26		10															
SB250M-2.5-40						34														
SB300-2.5-25.4			300		2.7	129.5	2.25	25.4	-					-	30	6.35	1.61	2200	2527	150.10-30
SB300M-2.5-25.4															40					
SB300-2.5-32						30		8												
SB300M-2.5-32									40											
SB300-2.5-40	30	10																		
SB300M-2.5-40				40																
SB300-2.5-40	122	3.0		97		40		90	11	30	10	2200	2530	150.10-30						
SB300M-2.5-40															40					

* Wrench for above holders sold separately.

Saw Blades

- Inserts P. 183 - 189
- Cutting Data P. 193 - 195

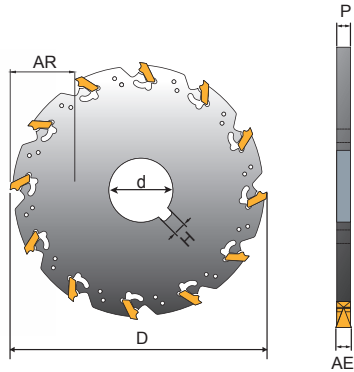

SB

Slitting

Order Code	Dimensions (mm)							Z	H	KG	MAX. RPM	Inserts LNGT	Wrench
	D	AE	AR	P	d	C	B						
SB050-3-13	50	3.0	14.5	2.7	13	-	-	4	-	0.10	12000	3030	150.10-30
SB050-3-12.7					12.7								
SB063-3-16	63	3.0	18	2.7	16	-	-	6	-	0.11	11000	3035	150.10-30
SB063-3-15.875					15.875								
SB080-3-22	80	3.0	22.5	2.7	22	-	-	8	6	0.13	8000	3030	150.10-30
SB080-3-25.4			19.5		25.4				6.35				
SB100-3-22	100	3.0	32.5	2.7	22	-	-	10	6	0.20	6300	3032	150.10-30
SB100-3-25.4			29.5		25.4				6.35				
SB100-3-27	100	3.2	29.5	2.7	27	-	-	10	7			3032	150.10-30
SB125-3-22	125	3.5	45	2.7	22	-	-	12	6	0.31	5000	3035	150.10-30
SB125-3-25.4			42		25.4				6.35				
SB125-3-32	125	3.5	39	2.7	32	-	-	12	8	0.31	5000	3035	150.10-30
SB160-3-25.4			59.5		25.4				6.35				
SB160-3-32	160	3.5	56.5	2.7	32	-	-	16	8	0.53	4000	3035	150.10-30
SB160-3-40			52		40				10				
SB200-3-25.4	200	3.5	79.5	2.7	25.4	-	-	20	6.35	0.85	3200	3035	150.10-30
SB200M-3-25.4								26					

* Wrench for above holders sold separately.

Saw Blades

- Inserts P. 183 - 189
- Cutting Data P. 193 - 195

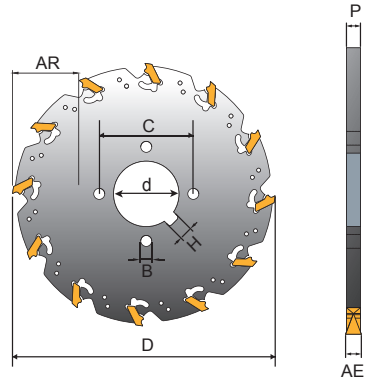
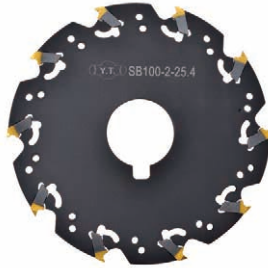

SB

Order Code	Dimensions (mm)							Z	H	KG	MAX. RPM	Inserts LNGT	Wrench
	D	AE	AR	P	d	C	B						
SB200-3-32	200	3.0	76.5	2.7	32	63	11	20	8	0.85	3200	3030	150.10-30
SB200M-3-32								26					
SB200-3-40			72		40	90		20	10				
SB200M-3-40								26					
SB250-3-25.4	250	3.0	104.5	2.7	25.4	-	11	26	6.35	1.38	2600	3032	150.10-30
SB250M-3-25.4								34					
SB250-3-32			101.5		32	63		26	8				
SB250M-3-32								34					
SB250-3-40			97		40	90		26	10				
SB250M-3-40								34					
SB300-3-25.4	300	3.2	129.5	2.7	25.4	-	11	30	6.35	1.86	2200	3035	150.10-30
SB300M-3-25.4								40					
SB300-3-32			126.5		32	63		30	8				
SB300M-3-32								40					
SB300-3-40			122		40	90		30	10				
SB300M-3-40								40					

* Wrench for above holders sold separately.

Saw Blades

- Inserts P. 183 - 189
- Cutting Data P. 193 - 195

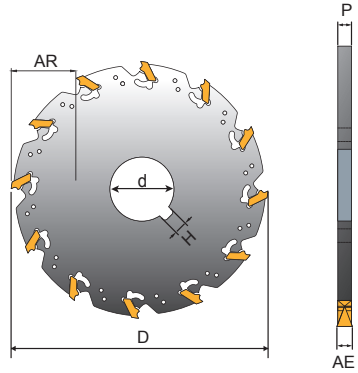

SB

Slitting

Order Code	Dimensions (mm)							Z	H	KG	MAX. RPM	Inserts LNGT	Wrench
	D	AE	AR	P	d	C	B						
SB050-4-13	50	4.0	14.5	3.7	13	-	-	4	-	0.09	12000	4040	150.10-30
SB050-4-12.7					12.7								
SB063-4-16	63	4.2	18	3.7	16	-	-	6	-	0.12	11000	4045	150.10-30
SB063-4-15.875					15.875								
SB080-4-22	80	4.5	22.5	3.7	22	-	-	8	6	0.15	8000	4040	150.10-30
SB080-4-25.4					25.4				6.35				
SB100-4-22	100	4.0	32.5	3.7	22	-	-	10	6	0.25	6300	4040	150.10-30
SB100-4-25.4					25.4				6.35				
SB100-4-27		4.2	29.5		27				7				
SB125-4-22	125	4.5	45	3.7	22	-	-	12	6	0.40	5000	4045	150.10-30
SB125-4-25.4					25.4				6.35				
SB125-4-32			39		32				8				
SB160-4-25.4	160	4.5	59.5	3.7	25.4	-	-	16	6.35	0.66	4000	4045	150.10-30
SB160-4-32					32				8				
SB160-4-40					40				10				
SB200-4-25.4	200	4.5	79.5	3.7	25.4	-	-	20	6.35	1.02	3200	4045	150.10-30
SB200M-4-25.4								26					

* Wrench for above holders sold separately.

Saw Blades

- Inserts P. 183 - 189
- Cutting Data P. 193 - 195

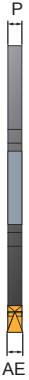
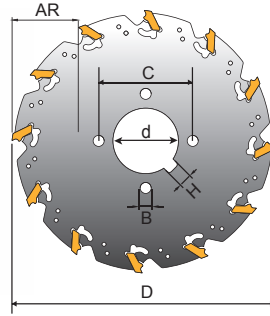

SB

Order Code	Dimensions (mm)							Z	H	KG	MAX. RPM	Inserts LNGT	Wrench
	D	AE	AR	P	d	C	B						
SB200-4-32	200	4.0	76.5	3.7	32	63	11	20	8	1.02	3200		
SB200M-4-32								26					
SB200-4-40			72		40	90		20	10				
SB200M-4-40								26					
SB250-4-25.4	250	4.0	104.5	3.7	25.4	-	11	26	6.35	1.69	2600	4040	150.10-30
SB250M-4-25.4								34					
SB250-4-32			101.5		32	63		26	8				
SB250M-4-32								34					
SB250-4-40			97		40	90		26	10				
SB250M-4-40								34					
SB300-4-25.4	300	4.2	129.5	3.7	25.4	-	11	30	6.35	2.18	2200	4042	150.10-30
SB300M-4-25.4								40					
SB300-4-32			126.5		32	63		30	8				
SB300M-4-32								40					
SB300-4-40			122		40	90		30	10				
SB300M-4-40								40					

* Wrench for above holders sold separately.

Saw Blades

- Inserts P. 183 - 189
- Cutting Data P. 193 - 195

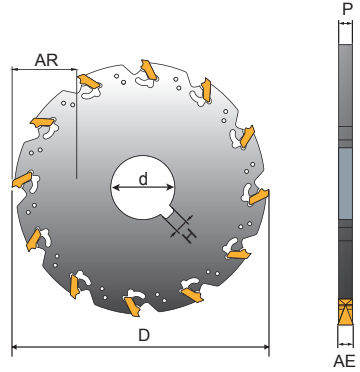

SB

Slitting

Order Code	Dimensions (mm)							Z	H	KG	MAX. RPM	Inserts LNGT	Wrench
	D	AE	AR	P	d	C	B						
SB050-5-13	50	5.0	14.5	4.5	13	-	-	4	-	0.13	12000	5050	150.10-30
SB050-5-12.7					12.7								
SB063-5-16	63	5.2	18	4.5	16	-	-	6	-	0.18	11000	5052	150.10-30
SB063-5-15.875					15.875								
SB080-5-22	80	5.5	22.5	4.5	22	-	-	8	6	0.18	8000	5055	150.10-30
SB080-5-25.4			19.5		25.4								
SB100-5-22	100	5.0	32.5	4.5	22	-	-	10	6	0.28	6300	5050	150.10-30
SB100-5-25.4		5.2	29.5		25.4				6.35				
SB100-5-27		5.5	27		7								
SB125-5-22	125	5.5	45	4.5	22	-	-	12	6	0.45	5000	5055	150.10-30
SB125-5-25.4			42		25.4				6.35				
SB125-5-32			39		32				8				
SB160-5-25.4	160	5.5	59.5	4.5	25.4	-	-	16	6.35	0.75	4000	5055	150.10-30
SB160-5-32			56.5		32				8				
SB160-5-40			52		40				10				

* Wrench for above holders sold separately.

ADAPTER HOLDER SERIES



Video

Features

Available in
materials



Cost
200~300%
SAVING

Applicable
Machines
Milling machine

Efficiency
300~500%
UP

Durability
300%
UP

New System For T-Slot Milling

ADAPTER HOLDER

Slotting

Slitting / Slotting / Cut-off

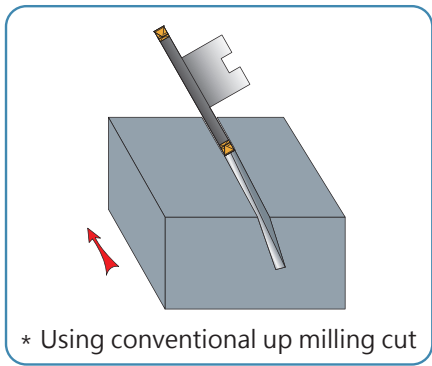
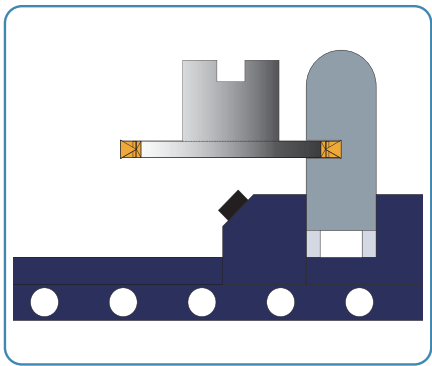
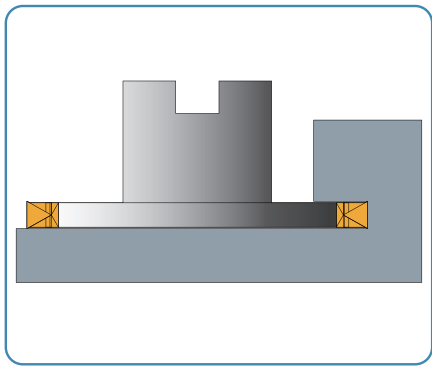
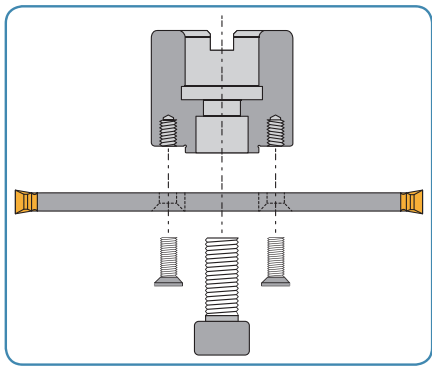

* Using conventional up milling cut

PRODUCT SPECIFICATIONS

Saw Milling Cutters

- Adapter Holders P. 154
- Inserts P. 183 - 189
- Cutting Data P. 193 - 195

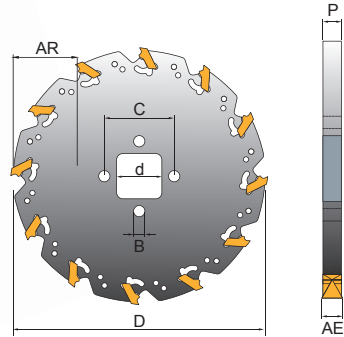

SBL

Order Code	Dimensions (mm)							Z	H	KG	MAX. RPM	Inserts LNGT	Wrench
	D	AE	AR	P	d	C	B						
SBL080-1.4-22	80	1.4	17	1.2	22	34	5	8	-	0.08	8000	1414	150.10-30
SBL100-1.4-22	100		27					32		46	6		
SBL125-1.4-32	125	1.5	33		16	0.18	5000						
SBL160-1.4-32	160	50.5	0.33			4000							
SBL080-1.6-22	80	1.6	17	1.4	22	34	5	8	-	0.09	8000	1616	150.10-30
SBL100-1.6-22	100		27					32		46	6		
SBL125-1.6-32	125		33		16	0.19	5000						
SBL160-1.6-32	160		50.5			0.35	4000						

* Wrench for above holders sold separately.

Saw Milling Cutters

- Adapter Holders P. 154
- Inserts P. 183 - 189
- Cutting Data P. 193 - 195

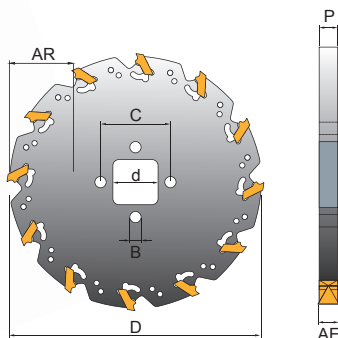

Slotting

SBL

Order Code	Dimensions (mm)							Z	H	KG	MAX. RPM	Inserts LNGT	Wrench
	D	AE	AR	P	d	C	B						
SBL080-1.8-22	80	1.8	17	1.6	22	34	5	8	-	0.10	8000	1818	150.10-30
SBL100-1.8-22	100		27					10		0.15	6300		
SBL125-1.8-32	125		33		12	0.21	5000						
SBL160-1.8-32	160		50.5		16	0.37	4000						
SBL080-2-22	80	2.0	17	1.75	22	34	5	8	-	0.10	8000	2020 2022 2025	150.10-30
SBL100-2-22	100		27					10		0.15	6300		
SBL125-2-32	125		2.2		33	12	0.22	5000					
SBL160-2-32	160		2.5		50.5	16	0.39	4000					
SBL080-2.5-22	80	2.5	17	2.25	22	34	5	8	-	0.11	8000	2525 2527 2530	150.10-30
SBL100-2.5-22	100		27					10		0.17	6300		
SBL125-2.5-32	125		2.7		33	12	0.26	5000					
SBL160-2.5-32	160		3.0		50.5	16	0.45	4000					

* Wrench for above holders sold seperately.

Saw Milling Cutters

- Adapter Holders P. 154
- Inserts P. 183 - 189
- Cutting Data P. 193 - 195

SBL

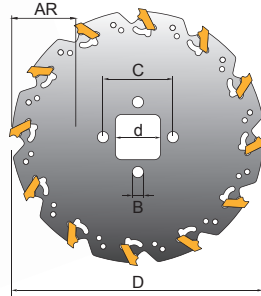

Order Code	Dimensions (mm)							Z	H	KG	MAX. RPM	Inserts LNGT	Wrench
	D	AE	AR	P	d	C	B						
SBL080-3-22	80	3.0	17	2.7	22	34	5	8	-	0.12	8000	3030 3032 3035	150.10-30
SBL100-3-22	100		27					10		0.20	6300		
SBL125-3-32	125		33					12		0.29	5000		
SBL160-3-32	160		50.5					16		0.51	4000		
SBL080-4-22	80	4.0	17	3.7	22	34	5	8	-	0.15	8000	4040 4042 4045	150.10-30
SBL100-4-22	100		27					10		0.24	6300		
SBL125-4-32	125		33					12		0.36	5000		
SBL160-4-32	160		50.5					16		0.64	4000		
SBL080-5-22	80	5.0	17	4.5	22	34	5	8	-	0.17	8000	5050 5052 5055	150.10-30
SBL100-5-22	100		27					10		0.27	6300		
SBL125-5-32	125		33					12		0.42	5000		
SBL160-5-32	160		50.5					16		0.74	4000		

* Wrench for above holders sold separately.

Side Milling Cutters

- Adapter Holders P. 154
- Inserts P. 190 - 192
- Cutting Data P. 196 - 197

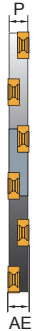
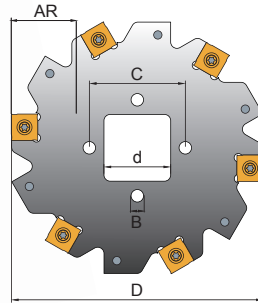

Slotting

STL

Order Code	Dimensions (mm)							Z	Zc	kg	MAX. RPM	Inserts SNGX SNGW	Screw	Key
	D	AE	AR	P	d	C	B							
STL080-4-22	80	4	17	3.4	22	34	5	8	4	0.16	13700	1102	T9354	T09P
STL080-5-22		5		4.2								1103	T9355	T08P
STL100-4-22	100	4	27	3.4	32	46	6	10	5	0.26	12000	1102	T9354	T09P
STL100-5-22		5		4.2								1103	T9355	T08P
STL125-4-32	125	4	33	3.4	32	46	6	12	6	0.37	10900	1102	T9354	T09P
STL125-5-32		5		4.2								1103	T9355	T08P
STL160-4-32	160	4	50.5	3.4	32	46	6	16	8	0.68	8300	1102	T9354	T09P
STL160-5-32		5		4.2								1103	T9355	T08P

* Use Zc (effective no. of teeth) to calculate the feed.

Adapter Holders

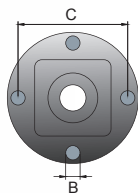

SBL/STL

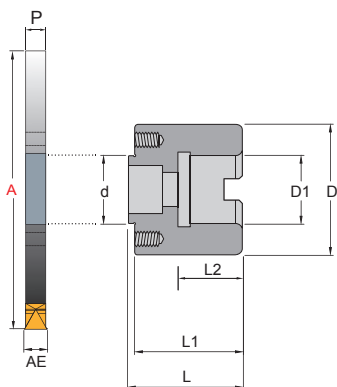

BL / BLL

Order Code	Dimensions (mm)									KG	Available P	
	D	D1	d	C	B	L	L1	L2	A			
BL45-22	45	22	22	34	5	43	41.8	27	80 100	0.47	 1.2-2.25mm	
BL45-25.4		25.4				45						43.8
BL58-31.75	58	31.75	32	46	6	55	53.8	28	125 160	0.95		
BL58-32		32				55						
BLL45-22	45	22	22	34	5	43	40.5	27	80 100	0.47		 2.7-4.5mm
BLL45-25.4		25.4				45						
BLL58-31.75	58	31.75	32	46	6	55	52.5	28	125 160	0.95		
BLL58-32		32				55						

* Please follow the step 1 · 2 · 3 to choose the cutter and holder to match: 1. Available P 2. "d" size 3. "D1" size.

Standard Spare Parts

Holder	Screw	Holder	Screw	Arbor Screw	
BL45-22	C90512	BLL45-22	C90512	M1035	
BL45-25.4		BLL45-25.4		M1235	
BL58-31.75	C90612	BLL58-31.75	C90612	M1235/M1635/ W2403	
BL58-32		BLL58-32		M1635	

SOLUTION-1

SBL/STL Series



Face Milling Arbor:
Better strength with shorter
length and bigger diameter

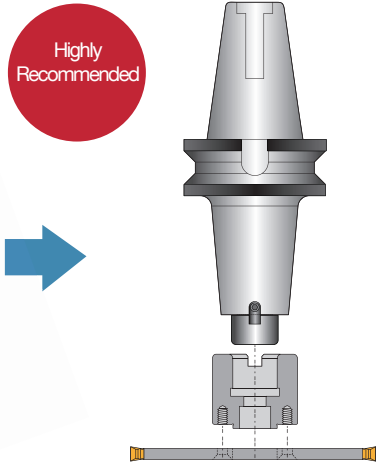

SOLUTION-2

SB Series



Side Milling Arbor:
Poor strength with longer
length and smaller diameter

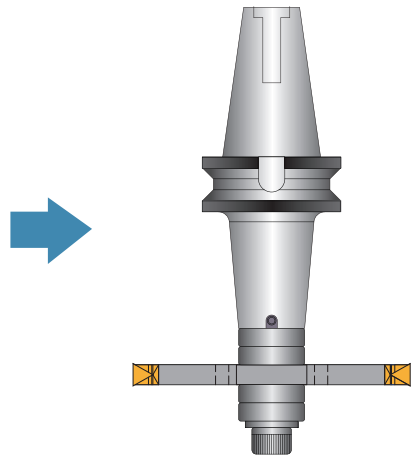

It might cause mechanism interferences.

ADAPTER HOLDER SERIES



Features

Available in materials



Cost
200~300%
SAVING

Applicable
Machines
Milling machine

Efficiency
300~500%
UP

Durability
300%
UP

PRODUCT SPECIFICATIONS

Side Milling Cutters

- Adapter Holders P. 160
- Inserts P.190 - 192
- Cutting Data P. 196 - 197

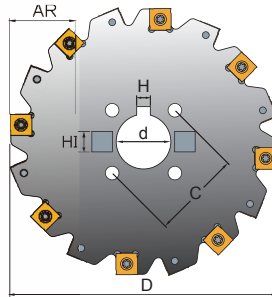

Slotting

SCL

Order Code	Dimensions (mm)								Z	Zc	KG	MAX. RPM	Inserts SNGX SNGW	Screw	Key
	D	AE	AR	P	H	C	d	HI							
SCL-160-6-32	160	6	46.5	5	8	52	32	16	8	0.87	8300	1203	T945	T15P	
SCL-160-8-32		8		7								12045	T947		
SCL-160-10-32		10		9								1205	T948		
SCL-160-12-32		12		11								1207	T9411		
SCL-200-6-40	200	6	54	5	10	70	40	18	9	1.34	4200	1203	T945	T15P	
SCL-200-8-40		8		7								12045	T947		
SCL-200-10-40		10		9								1205	T948		
SCL-200-12-40		12		11								1207	T9411		
SCL-250-6-40	250	6	79	5	10	70	40	24	12	2.05	3800	1203	T945	T15P	
SCL-250-8-40		8		7								12045	T947		
SCL-250-10-40		10		9								1205	T948		
SCL-250-12-40		12		11								1207	T9411		

* Use Zc (effective no. of teeth) to calculate the feed.

Disc Milling Cutters

- Adapter Holders P. 160
- Inserts P. 193
- Cutting Data P. 198-199

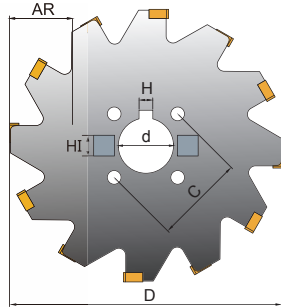

CEL

Order Code	Dimensions (mm)								Z	Zc		MAX. RPM	Inserts CNGX	Screw	Key
	D	AE	AR	P	H	C	d	HI							
CEL-160-14-32	160	14	46.5	12.5	8	52	32	12	6	1.72	6900	1005	C04011	T15P	
CEL-160-16-32		16		14.5						1.95					
CEL-160-18-32		18		16.5						2.19					
CEL-160-20-32		20		18.5						2.44		1305			
CEL-160-22-32		22		20.5						2.68					
CEL-160-25-32		25		23.5						3.04					
CEL-160-30-32		30		28.5						3.64		1605			
CEL-200-14-40	200	14	54	12.5	10	70	40	12	8	2.68	6100	1005	C04011	T15P	
CEL-200-16-40		16		14.5						3.06					
CEL-200-18-40		18		16.5						3.44					
CEL-200-20-40		20		18.5						3.82		1305			
CEL-200-22-40		22		20.5				4.20							
CEL-200-25-40		25		23.5				4.77	1605						
CEL-200-30-40		30		28.5				5.72							

* Use Zc (effective no. of teeth) to calculate the feed.

Disc Milling Cutters

- Adapter Holders P. 160
- Inserts P. 193
- Cutting Data P. 198 -199

CEL

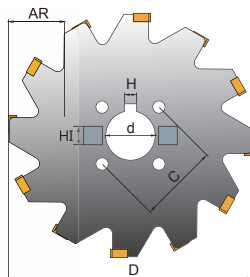

Order Code	Dimensions (mm)								Z	Zc	KG	MAX. RPM	Inserts CNGX	Screw	Key
	D	AE	AR	P	H	C	d	HI							
CEL-250-14-40	250	14	79	12.5	10	70	40	12X12	20	10	3.20	5500	1305	C04011	T15P
CEL-250-16-40		16		14.5							3.72				
CEL-250-18-40		18		16.5							4.24				
CEL-250-20-40		20		18.5							4.76				
CEL-250-22-40		22		20.5					5.28	16	8	6.06	7.36	1605	
CEL-250-25-40		25		23.5					6.06						
CEL-250-30-40		30		28.5					7.36						

* Use Zc (effective no. of teeth) to calculate the feed.

Back Milling Cutters

- Adapter Holders P. 160
- Inserts P. 193
- Cutting Data P. 198 -199

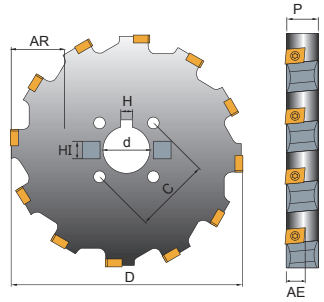

CWL

Order Code	Dimensions(mm)								Z	KG	MAX. RPM	Inserts CNGX	Screw	Key
	D	AE	AR	P	H	C	d	HI						
CWL-160-32	160	12	46.5	16.5	8	52	32	12X12	16	1.90	6900	1305	C04011	T15P
CWL-200-40	200		54		10	70	40		20	2.30	6100			
CWL-250-40	250		79						24	3.20	5500			

Adapter Holders

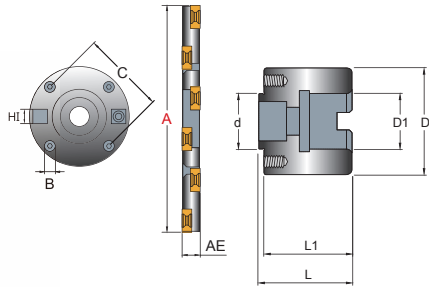

BCL

Order Code	Dimensions (mm)									KG
	D	D1	d	C	B	L	L1	A	HI	
BCL65-31.75M16	65	31.75	32	52	8	50	44.5	160	12X12	0.84
BCL65-32M16		32								
BCL65-38.1M16		38.1								
BCL65-40M16		40								
BCL90-38.1M16	90	38.1	40	70	8	60	54.5	200 250	12X12	1.70
BCL90-40M16		40								1.78
BCL90-50M16		50								1.80
BCL90-50.8M16		50.8								1.85
BCL90-60M16		60								1.90
BCL90-40M20		40								1.78
BCL90-50M20		50				1.80				
BCL90-60M20		60				1.90				
BCL90-40M20		65				40				1.78
BCL90-50M20						50				1.80
BCL90-60M20	60	1.90								

Standard Spare Parts

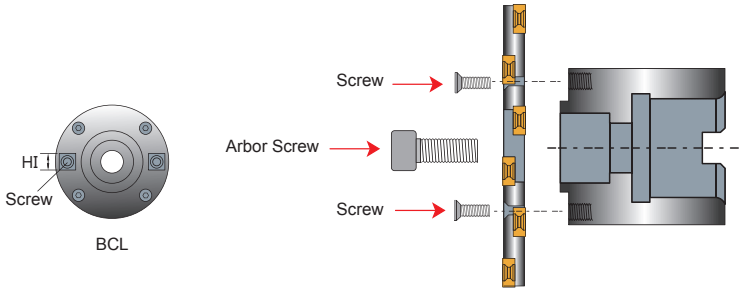

Slotting

Holders	Screw	Arbor Screw	HI+Screw	Holders	Screw	Arbor Screw	HI+Screw
SCL-160-6-32	C90815	M1635	W12.12.8 + M0510	CEL-160-14-32	C90820	M1635	W12.12.8 + M0510
SCL-160-8-32				CEL-160-16-32	C90825		
SCL-160-10-32	C90820	M1635	W12.12.8 + M0510	CEL-160-18-32	C90825	M1635	W12.12.8 + M0510
SCL-160-12-32	C90820			CEL-160-20-32	C90830		
SCL-200-6-40	C90815	M1635	W12.12.8 + M0510	CEL-160-22-32	C90830	M1635	W12.12.8 + M0510
SCL-200-8-40	C90815			CEL-160-25-32	C90835		
SCL-200-10-40	C90820	M2035	W12.12.8 + M0510	CEL-160-30-32	C90835	M1635	W12.12.8 + M0510
SCL-200-12-40	C90820			CEL-200-14-40	C90820		
SCL-250-6-40	C90815	M2035	W12.12.8 + M0510	CEL-200-16-40	C90820	M2035	W12.12.8 + M0510
SCL-250-8-40	C90815			CEL-200-18-40	C90825		
SCL-250-10-40	C90820	M2035	W12.12.8 + M0510	CEL-200-20-40	C90830	M1635	W12.12.8 + M0510
SCL-250-12-40				CEL-200-22-40	C90830		
CWL-160-32	C90825	M2035	W12.12.8 + M0510	CEL-200-25-40	C90835	M1635	W12.12.8 + M0510
CWL-200-40				CEL-200-30-40	C90835		
CWL-250-40				CEL-250-14-40	C90820		
				CEL-250-16-40	C90825		
				CEL-250-18-40	C90825		
				CEL-250-20-40	C90830		
				CEL-250-22-40	C90830		
				CEL-250-25-40	C90835		
				CEL-250-30-40	C90835		

SIDE MILLING CUTTER

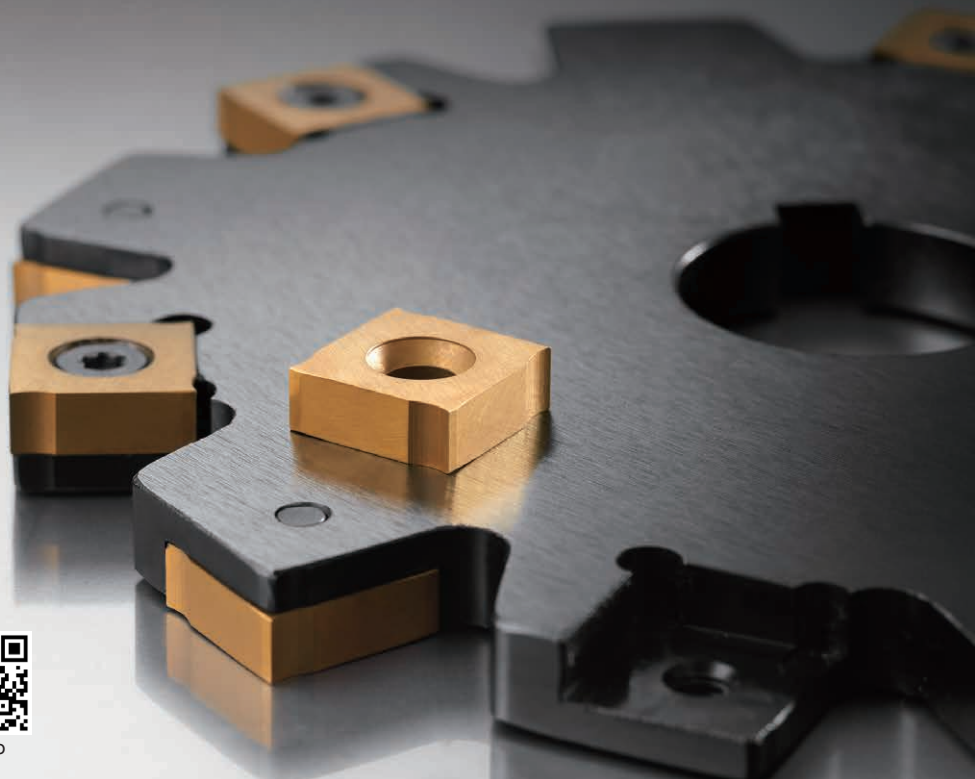

Video

Features

Available in materials



Cost
200~300%
SAVING

Applicable
Machines
Milling machine

Efficiency
300~500%
UP

Durability
300%
UP

PRODUCT SPECIFICATIONS

Side Milling Cutters

- Inserts P. 190 - 192
- Cutting Data P. 196 - 197

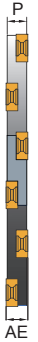
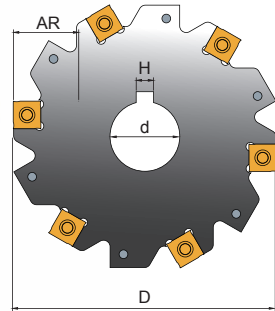

Slotting

SC

Order Code	Dimensions (mm)						Z	Zc	KG	MAX. RPM	Inserts SNGX SNGW	Screw	Key
	D	AE	AR	P	H	d							
SC-80-4-22	80	4	22.5	3.4	6	22	8	4	13700	1102	T9354	T09P	
SC-80-5-22		5		4.2						1103	T9355	T08P	
SC-80-6-22		6		5						1203	T945	T15P	
SC-80-7-22		7	6	1204						T946			
SC-80-8-22		8	7	12045						T947			
SC-80-10-22		10	9	1205						T948			
SC-80-12-22		12	11	1207	T9411								
SC-80-4-25.4		4	19.5	3.4	6.35	25.4				1102	T9354	T09P	
SC-80-5-25.4		5		4.2						1103	T9355	T08P	
SC-80-6-25.4		6		5						1203	T945	T15P	
SC-80-7-25.4		7		6						1204	T946		
SC-80-8-25.4		8		7						12045	T947		
SC-80-10-25.4	10	9		1205			T948						
SC-80-12-25.4	12	11	1207	T9411									

* Use Zc (effective no. of teeth) to calculate the feed.

Side Milling Cutters

- Inserts P. 190 - 192
- Cutting Data P. 196 - 197

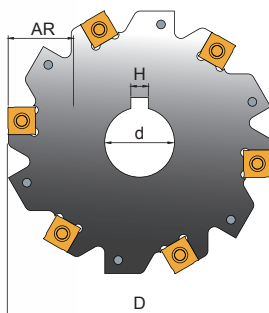

SC

Order Code	Dimensions (mm)						Z	Zc	kg	MAX. RPM	Inserts SNGX SNGW	Screw	Key		
	D	AE	AR	P	H	d									
SC-100-4-25.4	100	4	29.5	3.4	6.35	25.4	10	5	12000	0.23	1102	T9354	T09P		
SC-100-5-25.4		5		4.2						7	27	0.26	1103	T9355	T08P
SC-100-6-25.4		6		5								0.32	1203	T945	T15P
SC-100-7-25.4		7		6								0.36	1204	T946	
SC-100-8-25.4		8		7								0.39	12045	T947	
SC-100-10-25.4		10		9								0.46	1205	T948	
SC-100-12-25.4		12		11	0.54	1207				T9411					
SC-100-4-27		4		3.4	7	27				0.23	1102	T9354	T09P		
SC-100-5-27		5		4.2						0.26	1103	T9355	T08P		
SC-100-6-27		6		5						0.31	1203	T945	T15P		
SC-100-7-27		7		6						0.35	1204	T946			
SC-100-8-27		8		7						0.39	12045	T947			
SC-100-10-27	10	9	0.46	1205			T948								
SC-100-12-27	12	11	0.53	1207			T9411								

* Use Zc (effective no. of teeth) to calculate the feed.

Side Milling Cutters

- Inserts P. 190 - 192
- Cutting Data P. 196 - 197

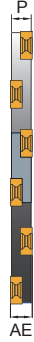
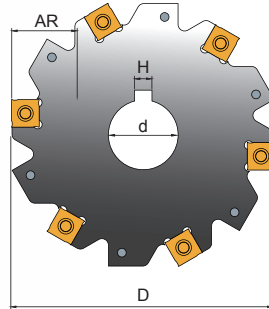

Slotting

SC

Order Code	Dimensions (mm)						Z	Zc	KG	MAX. RPM	Inserts SNGX SNGW	Screw	Key
	D	AE	AR	P	H	d							
SC-125-4-32	125	4	39	3.4	8	32	12	6	10900	1102	T9354	T09P	
SC-125-5-32		5		4.2						T1103	T9355	T08P	
SC-125-6-32		6		5						1203	T945	T15P	
SC-125-7-32		7		6						1204	T946		
SC-125-8-32		8		7						12045	T947		
SC-125-10-32		10		9						1205	T948		
SC-125-12-32		12	11	1207	T9411								
SC-125-4-40		4	34.5	3.4	10	40				1102	T9354	T09P	
SC-125-5-40		5		4.2						1103	T9355	T08P	
SC-125-6-40		6		5						1203	T945	T15P	
SC-125-7-40		7		6						1204	T946		
SC-125-8-40		8		7						12045	T947		
SC-125-10-40	10	9		1205			T948						
SC-125-12-40	12	11		1207			T9411						

* Use Zc (effective no. of teeth) to calculate the feed.

Side Milling Cutters

- Inserts P. 190 - 192
- Cutting Data P. 196 - 197

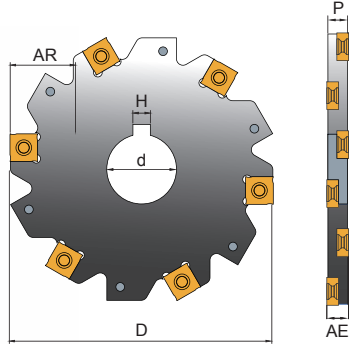

SC

Order Code	Dimensions (mm)						Z	Zc	KG	MAX. RPM	Inserts SNGX SNGW	Screw	Key						
	D	AE	AR	P	H	d													
SC-125-4-25.4	125	4	42	3.4	6.35	25.4	12	6	10900	1102	T9354	T09P							
SC-125-5-25.4		5		4.2						T1103	T9355	T08P							
SC-125-6-25.4		6		5						1203	T945	T15P							
SC-125-7-25.4		7		6						1204	T946								
SC-125-8-25.4		8		7						12045	T947								
SC-125-10-25.4		10		9						1205	T948								
SC-125-12-25.4		12		11						1207	T9411								
SC-125-4-31.75		31.75		4						39	3.4	8	31.75	12	6	10900	1102	T9354	T09P
SC-125-5-31.75				5							4.2						T1103	T9355	T08P
SC-125-6-31.75				6							5						1203	T945	T15P
SC-125-7-31.75	7		6	1204	T946														
SC-125-8-31.75	8		7	12045	T947														
SC-125-10-31.75	10		9	1205	T948														
SC-125-12-31.75	12		11	1207	T9411														

* Use Zc (effective no. of teeth) to calculate the feed.

Side Milling Cutters

- Inserts P. 190 - 192
- Cutting Data P. 196 - 197

SC

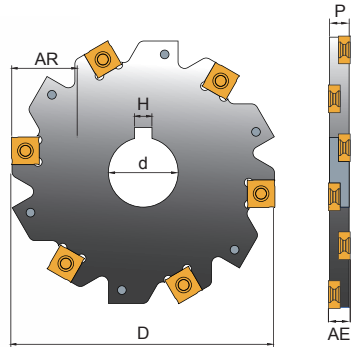

Slotting

Order Code	Dimensions (mm)						Z	Zc	KG	MAX. RPM	Inserts SNGX SNGW	Screw	Key
	D	AE	AR	P	H	d							
SC-160-4-32	160	4	56.5	3.4	8	32	16	8	8300	1102	T9354	T09P	
SC-160-5-32		5		4.2						T9355	T08P		
SC-160-6-32		6		5						1203	T945	T15P	
SC-160-7-32		7		6						1204	T946		
SC-160-8-32		8		7						12045	T947		
SC-160-10-32		10		9						1205	T948		
SC-160-12-32		12	11	1207	T9411								
SC-160-4-40		4	52	3.4	10	40				1102	T9354		T09P
SC-160-5-40		5		4.2						1103	T9355	T08P	
SC-160-6-40		6		5						1203	T945	T15P	
SC-160-7-40		7		6						1204	T946		
SC-160-8-40		8		7						12045	T947		
SC-160-10-40	10	9		1205			T948						
SC-160-12-40	12	11	1207	T9411									

* Use Zc (effective no. of teeth) to calculate the feed.

Side Milling Cutters

- Inserts P. 190 - 192
- Cutting Data P. 196 - 197

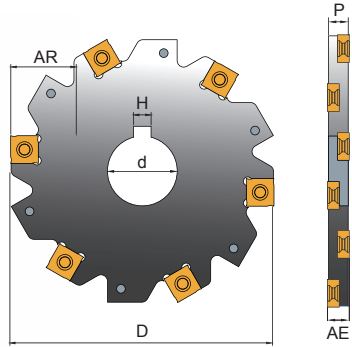

SC

Order Code	Dimensions (mm)						Z	Zc	 MAX. RPM	Inserts SNGX SNGW	Screw	Key
	D	AE	AR	P	H	d						
SC-160-4-25.4	160	4	59.5	3.4	6.35	25.4	16	8	8300	1102	T9354	T09P
SC-160-5-25.4		5		4.2						T9355	T08P	
SC-160-6-25.4		6		5						T15P		
SC-160-7-25.4		7		6								
SC-160-8-25.4		8		7								
SC-160-10-25.4		10		9								
SC-160-12-25.4		12	11									
SC-160-4-31.75		4	56.5	3.4	8	31.75				1102	T9354	T09P
SC-160-5-31.75		5		4.2						T9355	T08P	
SC-160-6-31.75		6		5						T15P		
SC-160-7-31.75		7		6								
SC-160-8-31.75		8		7								
SC-160-10-31.75	10	9										
SC-160-12-31.75	12	11										

* Use Zc (effective no. of teeth) to calculate the feed.

Side Milling Cutters

- Inserts P. 190 - 192
- Cutting Data P. 196 - 197

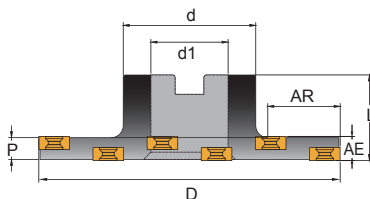

Slotting

ST

Order Code	Dimensions (mm)							Z	Zc	KG	MAX. RPM	Inserts SNGX SNGW	Screw	Key
	D	AE	AR	P	d	d1	L							
ST-80-6-22	80	6	17	5	40	22	8	4	0.47	13700	1203	T945	T15P	
ST-80-7-22		7		6							1204	T946		
ST-80-8-22		8		7							12045	T947		
ST-80-10-22		10		9							1205	T948		
ST-80-12-22		12		11							1207	T9411		
ST-100-6-27	100	6	27	5	35	27	10	5	0.56	12000	1203	T945		
ST-100-7-27		7		6							1204	T946		
ST-100-8-27		8		7							12045	T947		
ST-100-10-27		10		9							1205	T948		
ST-100-12-27		12		11							1207	T9411		
ST-125-6-32	125	6	31	5	55	32	12	6	0.96	10900	1203	T945		
ST-125-7-32		7		6							1204	T946		
ST-125-8-32		8		7							12045	T947		
ST-125-10-32		10		9							1205	T948		
ST-125-12-32		12		11							1207	T9411		
ST-160-6-32	160	6	48.5	5	35	32	16	8	1.42	8300	1203	T945		
ST-160-7-32		7		6							1204	T946		
ST-160-8-32		8		7							12045	T947		
ST-160-10-32		10		9							1205	T948		
ST-160-12-32		12		11							1207	T9411		

* Use Zc (effective no. of teeth) to calculate the feed.

Side Milling Cutters

- Inserts P. 190 - 192
- Cutting Data P. 196 - 197

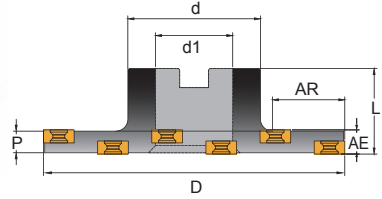

ST

Order Code	Dimensions (mm)							Z	Zc	KG	MAX. RPM	Inserts SNGX SNGW	Screw	Key
	D	AE	AR	P	d	d1	L							
ST-80-6-25.4	80	6	17	5	40	25.4	8	4	13700	1203	T945	T15P		
ST-80-7-25.4		7		6										
ST-80-8-25.4		8		7										
ST-80-10-25.4		10		9										
ST-80-12-25.4		12		11										
ST-100-6-25.4	100	6	27	5	35	35	10	5	12000	1203	T945			
ST-100-7-25.4		7		6										
ST-100-8-25.4		8		7										
ST-100-10-25.4		10		9										
ST-100-12-25.4		12		11										
ST-125-6-31.75	125	6	31	5	55	31.75	12	6	10900	1203	T945			
ST-125-7-31.75		7		6										
ST-125-8-31.75		8		7										
ST-125-10-31.75		10		9										
ST-125-12-31.75		12		11										
ST-160-6-31.75	160	6	48.5	5	35	35	16	8	8300	1203	T945			
ST-160-7-31.75		7		6										
ST-160-8-31.75		8		7										
ST-160-10-31.75		10		9										
ST-160-12-31.75		12		11										

* Use Zc (effective no. of teeth) to calculate the feed.

DISC MILLING CUTTER



Features

Available in materials



Cost
200~300%
SAVING

Applicable
Machines
Milling machine

Efficiency
300~500%
UP

Durability
300%
UP

PRODUCT SPECIFICATIONS

Disc Milling Cutters

- Inserts P. 193
- Cutting Data P. 198 - 199

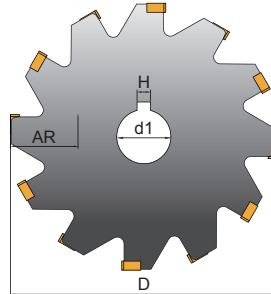

CE

Order Code	Dimensions (mm)						Z	Zc	KG	MAX. RPM	Inserts CNGX	Screw	Key
	D	AE	AR	P	H	d1							
CE080-14-22	80	14	22.5	12.5	6	22	8	4	0.45	13700	1005	C04011	T15P
CE080-16-22		16		14.5					0.51				
CE080-18-22		18		16.5					0.54				
CE080-20-22		20		18.5					0.59		1305		
CE080-22-22		22		20.5					0.69				
CE080-25-22		25		23.5					0.75				
CE080-30-22		30		28.5					0.88				
CE100-14-27	100	14	29.5	12.5	7	27	10	5	0.67	12000	1005		
CE100-16-27		16		14.5					0.76		1305		
CE100-18-27		18		16.5					0.84				

* Use Zc (effective no. of teeth) to calculate the feed.

Disc Milling Cutters

- Inserts P. 193
- Cutting Data P. 198 - 199

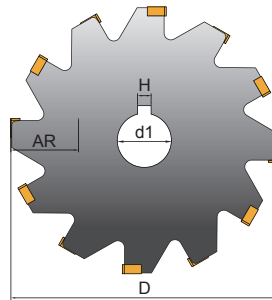

Slotting

CE

Order Code	Dimensions (mm)						Z	Zc	KG	MAX. RPM	Inserts CNGX	Screw	Key			
	D	AE	AR	P	H	d1										
CE100-20-27	100	20	29.5	18.5	7	27	10	5	0.91	12000	1305	C04011	T15P			
CE100-22-27		22		20.5					1.01							
CE100-25-27		25		23.5					1.16		1605					
CE100-30-27		30		28.5					1.40							
CE125-14-32	125	14	39	12.5	8	32	12	6	1.02	10900	1005	C04011	T15P			
CE125-16-32		16		14.5					1.17							
CE125-18-32		18		16.5					1.36							
CE125-20-32		20	18.5	1.52	1305											
CE125-22-32		22	20.5	1.57												
CE125-25-32		25	23.5	1.85	1605											
CE125-30-32		30	28.5	1.92												
CE080-14-25.4		80	14	19.5	12.5	6.35	25.4	8	4	0.45	13700			1005	C04011	T15P
CE080-16-25.4			16		14.5					0.51						
CE080-18-25.4			18		16.5					0.54				1305		
CE080-20-25.4	20		18.5		0.59											
CE080-22-25.4	22		20.5		0.69											

* Use Zc (effective no. of teeth) to calculate the feed.

Disc Milling Cutters

- Inserts P. 193
- Cutting Data P. 198 - 199

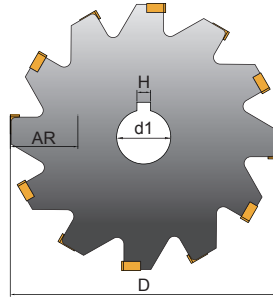

CE

Order Code	Dimensions (mm)						Z	Zc		MAX. RPM	Inserts CNGX	Screw	Key	
	D	AE	AR	P	H	d1								
CE080-25-25.4	80	25	19.5	23.5	6.35	25.4	8	4	0.75	13700	1605	C04011	T15P	
CE080-30-25.4		30		28.5										0.88
CE100-14-25.4	100	14	29.5	12.5			10	5	0.67	12000	1005			
CE100-16-25.4		16		14.5										0.76
CE100-18-25.4		18		16.5										0.84
CE100-20-25.4		20		18.5										0.91
CE100-22-25.4		22		20.5							1.01			1305
CE100-25-25.4		25		23.5							1.16			
CE100-30-25.4		30		28.5							1.40			
CE125-14-25.4		125		14							42			
CE125-16-25.4	16		14.5	1.17										
CE125-18-25.4	18		16.5	1.36										
CE125-20-25.4	20		18.5	1.52										
CE125-22-25.4	22		20.5	1.57	1305									
CE125-25-25.4	25		23.5	1.85										
CE125-30-25.4	30		28.5	1.92										
CE125-25-25.4												1605		

* Use Zc (effective no. of teeth) to calculate the feed.

Disc Milling Cutters

- Inserts P. 193
- Cutting Data P. 198 - 199

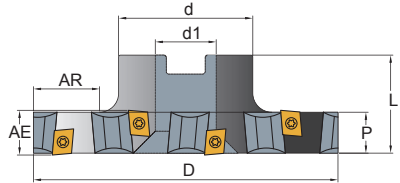

CW

Slotting

Order Code	Dimensions (mm)							Z	Zc	kg	MAX. RPM	Inserts CNGX	Screw	Key					
	D	AE	AR	P	d	d1	L												
CW080-14-22	80	14	17	12.5	40	22	35	8	4	0.67	13700	1005	C04011	T15P					
CW080-16-22		16		14.5						0.72									
CW080-18-22		18		16.5						0.76									
CW080-20-22		20		18.5						45		27			40	10	5	0.78	1305
CW080-22-22		22		20.5						1.09									
CW080-25-22		25		23.5						1.17									
CW080-30-22		30		28.5						1.25		1605							
CW100-14-27	100	14	24.5	12.5	55	32	35	12	6	0.84	10900	1005	C04011	T15P					
CW100-16-27		16		14.5						0.94									
CW100-18-27		18		16.5						1.02									
CW100-20-27		20		18.5						45		27			40	10	5	1.09	1305
CW100-22-27		22		20.5						1.17									
CW100-25-27		25		23.5						1.25									
CW100-30-27		30		28.5						1.32		1605							
CW125-14-32	125	14	32	12.5	55	32	35	12	6	1.42	10900	1005	C04011	T15P					
CW125-16-32		16		14.5						1.53									

* Use Zc (effective no. of teeth) to calculate the feed.

Disc Milling Cutters

- Inserts P. 193
- Cutting Data P. 198 - 199

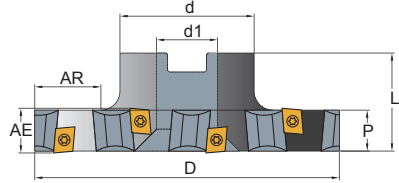

CW

Order Code	Dimensions (mm)							Z	Zc	KG	MAX. RPM	Inserts CNGX	Screw	Key
	D	AE	AR	P	d	d1	L							
CW125-18-32	125	18	32	16.5	55	32	35	12	6	1.68	10900	C04011	T15P	
CW125-20-32		20		18.5						40				1.92
CW125-22-32		22		20.5										1.94
CW125-25-32		25		23.5										1.96
CW125-30-32		30		28.5			2.29							
CW080-14-25.4	80	14	17	12.5	40	35	8	4	0.67	13700	C04011	T15P		
CW080-16-25.4		16		14.5					40				0.72	
CW080-18-25.4		18		16.5									0.76	
CW080-20-25.4		20		18.5		25.4			0.78				1605	
CW080-22-25.4		22		20.5					0.79					
CW080-25-25.4		25		23.5					0.85					
CW080-30-25.4		30		28.5					0.92					
CW100-14-25.4	100	14	24.5	12.5	45	35	10	5	0.86	12000	C04011	T15P		
CW100-16-25.4		16		14.5					0.94					
CW100-18-25.4		18		16.5					1.02					
CW100-20-25.4		20		18.5					1.09					

* Use Zc (effective no. of teeth) to calculate the feed.

Disc Milling Cutters

- Inserts P. 193
- Cutting Data P. 198 - 199

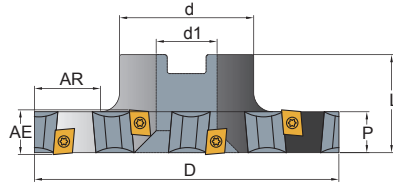

CW

Slotting

Order Code	Dimensions (mm)							Z	Zc	KG	MAX. RPM	Inserts CNGX	Screw	Key
	D	AE	AR	P	d	d1	L							
CW100-22-25.4	100	22	24.5	20.5	45	25.4	35	10	5	1.17	12000	1305	C04011	T15P
CW100-25-25.4		25		23.5						1.25		1605		
CW100-30-25.4		30		28.5						1.32		1605		
CW125-14-31.75	125	14	32	12.5	55	31.75	35	12	6	1.42	10900	1005	C04011	T15P
CW125-16-31.75		16		14.5						1.53		1305		
CW125-18-31.75		18		16.5						1.68		1305		
CW125-20-31.75		20		18.5						1.92		1305		
CW125-22-31.75		22		20.5						1.94		1305		
CW125-25-31.75		25		23.5						1.96		1605		
CW125-30-31.75		30		28.5						2.29		1605		
CW125-40-31.75		40		38.5						2.54		1605		

* Use Zc (effective no. of teeth) to calculate the feed.

Mounting Dimensions

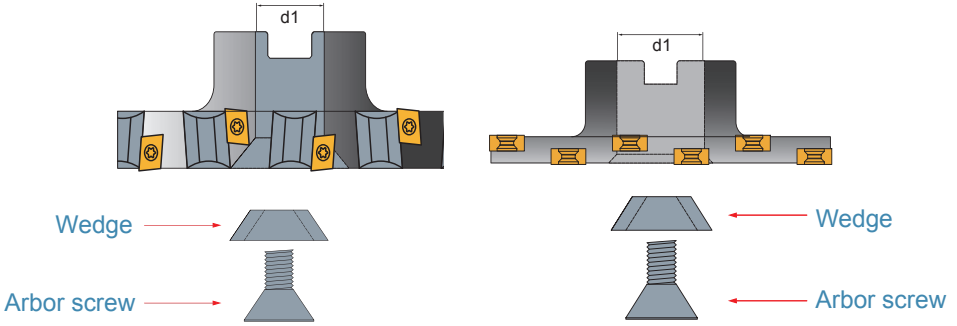

Dimension (mm)		
Cutter dimension d_1	Arbor screw	Tapered Wedge
ST $\varnothing 22$	C901035	WE30
ST $\varnothing 27$	C901235	
ST $\varnothing 32$	C901635	WE45
ST $\varnothing 25.4$	C901235	WE30
ST $\varnothing 31.75$	C901235, C901635	WE30, WE45
CW $\varnothing 22$	C901035	WE30
CW $\varnothing 27$	C901235	
CW $\varnothing 32$	C901635	WE45
CW $\varnothing 40$	C901640	WE63
CW $\varnothing 25.4$	C901235	WE30
CW $\varnothing 31.75$	C901235, C901635	WE30, WE45
CW $\varnothing 38.1$	C901635	WE63
CW $\varnothing 50.8$		

* Cutter price includes the wedge.

BACK AND STRADDLE



Features

Available in materials

A circular icon containing six smaller colored circles with letters: P (blue), K (orange), M (yellow), N (green), S (grey), and H (red).

Cost
200~300%
SAVING

Applicable
Machines
Milling machine

Efficiency
300~500%
UP

Durability
300%
UP

PRODUCT SPECIFICATIONS

Back milling Cutters

- Inserts P. 193
- Cutting Data P. 198 - 199

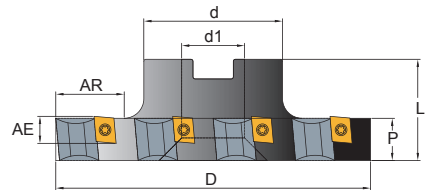
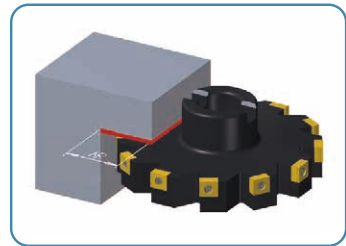

CB

Order Code	Dimensions (mm)							Z	 KG	MAX. RPM	Insert CNGX	Screw	Key
	D	AE	P	d	d1	L	AR						
CB-100-27	100	12	16.5	45	27	35	24.5	10	0.97	12000	1305	C04011	T15P
CB-125-32	125			55	32		32						

Straddle milling cutters

- Inserts P. 193
- Cutting Data P. 198 - 199

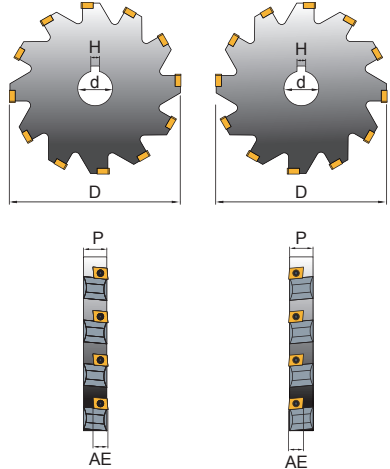
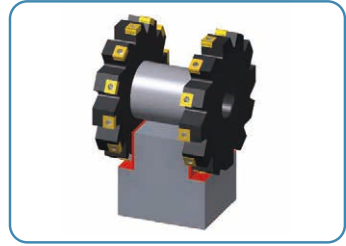

CDL / CDR

Order Code	Dimensions (mm)						Z	KG	MAX. RPM	Insert CNGX	Screw	Key
	D	AE	P	d	H	L/R						
CDL-100-27	100			27	7	L	10	0.87	12000			
CDR-100-27						R						
CDL-125-32	125	12	16.5	32	8	L	12	1.42	10900	1305	C04011	T15P
CDR-125-32						R						
CDL-160-40	160			40	10	L	16	2.52	6900			
CDR-160-40						R						

Back & Straddle

SLITTING/ SLOTTING/ CUT-OFF SERIES Inserts

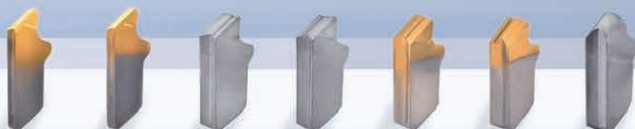
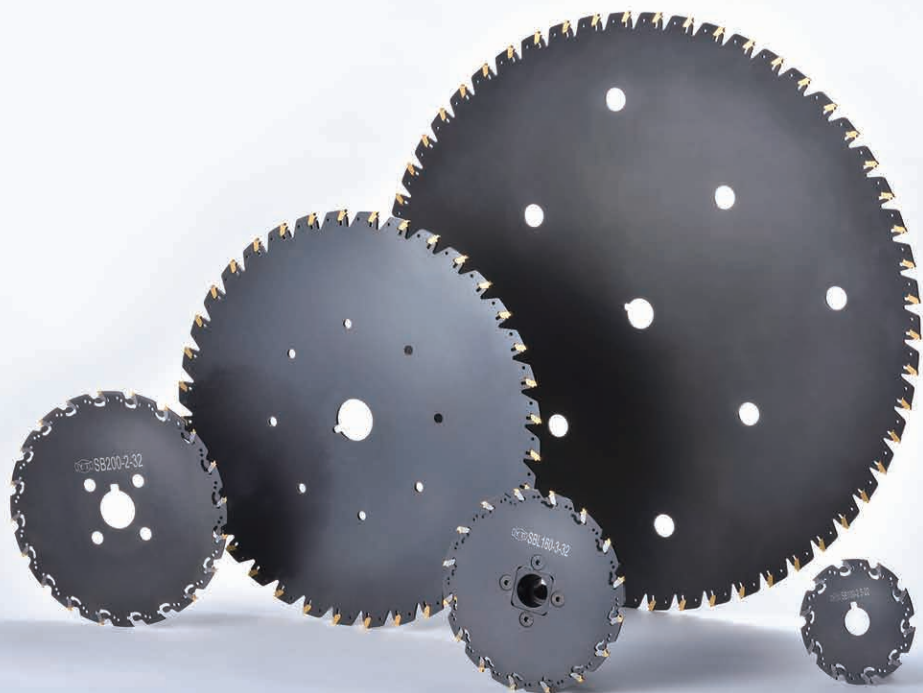

NRS / NLS

NR / NL

R

LNGT Inserts

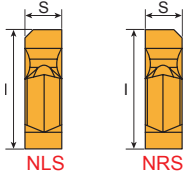

Tolerances (mm)
S=±0.02



Inserts 10 PCS / Box

Dimensions (mm)		
Blade Thickness	S	I
1.2	1.4	9
1.2	1.5	
1.4	1.6	

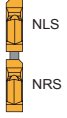
Inserts	Order Code	Grades								 EE		
		Carbide					Cermet		Uncoated			
		B100	C200	C250	F20	F30	CE100	CE60	K10		CE	
NLS	LNGT 1414NLS-EE											Inserts Sequencing Position  (Interleaving one after another different one.)
	LNGT 1415NLS-EE											
	LNGT 1616NLS-EE											
NRS	LNGT 1414NRS-EE											
	LNGT 1415NRS-EE											
	LNGT 1616NRS-EE											

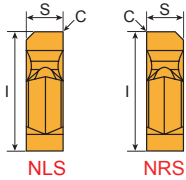

Tolerances (mm)
S=±0.02



Inserts 10 PCS / Box

Dimensions (mm)			
Blade Thickness	S	I	C
1.2	1.4	9	0.03
1.2	1.5		
1.4	1.6		

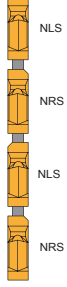
Inserts	Order Code	Grades								 M ME		
		Carbide					Cermet		Uncoated			
		B100	C200	C250	F20	F30	CE100	CE60	K10		CE	
NLS	LNGT 1414NLS-M											Inserts Sequencing Position  (Interleaving one after another different one.)
	LNGT 1415NLS-M											
	LNGT 1616NLS-M											
	LNGT 1414NLS-ME											
	LNGT 1415NLS-ME											
	LNGT 1616NLS-ME											
NRS	LNGT 1414NRS-M											
	LNGT 1415NRS-M											
	LNGT 1616NRS-M											
	LNGT 1414NRS-ME											
	LNGT 1415NRS-ME											
	LNGT 1616NRS-ME											

- Steel Stainless Steel Steel/Stainless Steel /Super alloy Cast Iron Aluminum Steel/Cast Iron
- Steel/Stainless Steel/Cast Iron
- Prices and stocks are based on present conditions
- Please specify model numbers and the grade of inserts, ie.: LNGT 1414NLS-M,B100

LNGT Inserts

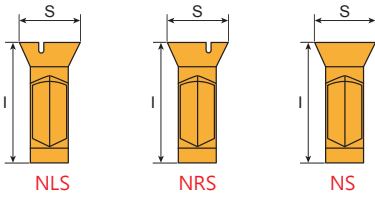

← Only applicable in cutter width 6,8mm

Tolerances (mm)
S = ±0.02

Dimensions (mm)		
Blade Thickness	S	I
1.6	1.8	9
1.75	2.0, 2.2, 2.5	
2.25	2.5, 2.7, 3.0	
2.7	3.0, 3.2, 3.5	
3.7	4.0, 4.2, 4.5	
4.5	5.0, 5.2, 5.5	

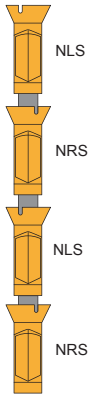
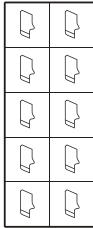
Inserts	Order Code	Grades											
		Carbide					Cermet		Uncoated				
		B100	C200	C250	F20	F30	CE100	CE60	K10	OE			
NLS	LNGT 1818NLS-EE												Inserts Sequencing Position 
	LNGT 2020NLS-EE												
	LNGT 2022NLS-EE												
	LNGT 2025NLS-EE												
	LNGT 2525NLS-EE												
	LNGT 2527NLS-EE												
	LNGT 2530NLS-EE												
	LNGT 3030NLS-EE												
	LNGT 3032NLS-EE												
	LNGT 3035NLS-EE												
	LNGT 4040NLS-EE												
	LNGT 4042NLS-EE												
	LNGT 4045NLS-EE												
	LNGT 5050NLS-EE												
LNGT 5052NLS-EE													
LNGT 5055NLS-EE													
NRS	LNGT 1818NRS-EE												(Interleaving one after another different one.) 
	LNGT 2020NRS-EE												
	LNGT 2022NRS-EE												
	LNGT 2025NRS-EE												
	LNGT 2525NRS-EE												
	LNGT 2527NRS-EE												
	LNGT 2530NRS-EE												
	LNGT 3030NRS-EE												
	LNGT 3032NRS-EE												
	LNGT 3035NRS-EE												
	LNGT 4040NRS-EE												
	LNGT 4042NRS-EE												
	LNGT 4045NRS-EE												
	LNGT 5050NRS-EE												
LNGT 5052NRS-EE													
LNGT 5055NRS-EE													
NS	LNGT 5050NS-EE												Inserts 10 PCS / Box

- Steel Stainless Steel Steel/Stainless Steel /Super alloy Cast Iron Aluminum Steel/Cast Iron
- Steel/Stainless Steel/Cast Iron
- Prices and stocks are based on present conditions
- Please specify model numbers and the grade of inserts, ie.: LNGT 2020NLS-EE, F20

LNGT Inserts

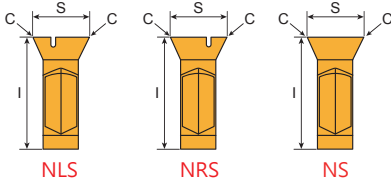

Only applicable in cutter width 6,8mm

Tolerances (mm)
S: ±0.02

Dimensions (mm)			
Blade Thickness	S	I	C
1.6	1.8	9	0.05
1.75	2.0, 2.2, 2.5		
2.25	2.5, 2.7, 3.0		
2.7	3.0, 3.2, 3.5		
3.7	4.0, 4.2, 4.5		
4.5	5.0, 5.2, 5.5		

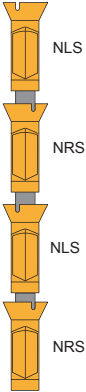
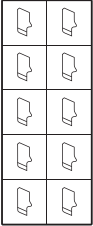
Inserts	Order Code	Grades										
		Carbide					Cermet		Uncoated			
		B100	C200	C250	F20	F30	CE100	CE60	K10	CE		
NLS	LNGT 1818NLS-M											 <p>Inserts Sequencing Position</p> <p>(Interleaving one after another different one.)</p>  <p>Inserts 10 PCS / Box</p>
	LNGT 2020NLS-M											
	LNGT 2022NLS-M											
	LNGT 2025NLS-M											
	LNGT 2525NLS-M											
	LNGT 2527NLS-M											
	LNGT 2530NLS-M											
	LNGT 3030NLS-M											
	LNGT 3032NLS-M											
	LNGT 3035NLS-M											
	LNGT 4040NLS-M											
	LNGT 4042NLS-M											
	LNGT 4045NLS-M											
	LNGT 5050NLS-M											
LNGT 5052NLS-M												
LNGT 5055NLS-M												
NRS	LNGT 1818NRS-M											
	LNGT 2020NRS-M											
	LNGT 2022NRS-M											
	LNGT 2025NRS-M											
	LNGT 2525NRS-M											
	LNGT 2527NRS-M											
	LNGT 2530NRS-M											
	LNGT 3030NRS-M											
	LNGT 3032NRS-M											
	LNGT 3035NRS-M											
	LNGT 4040NRS-M											
	LNGT 4042NRS-M											
	LNGT 4045NRS-M											
LNGT 5050NRS-M												
LNGT 5052NRS-M												
LNGT 5055NRS-M												
NS	LNGT 5050NS-M											

- Steel Stainless Steel Steel/Stainless Steel /Super alloy Cast Iron Aluminum Steel/Cast Iron
- Steel/Stainless Steel/Cast Iron

- Prices and stocks are based on present conditions
- Please specify model numbers and the grade of inserts, ie.: LNGT 2020NLS-M,B100

LNGT Inserts

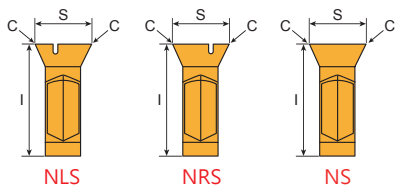

Tolerances (mm)
S : ±0.02

Only applicable in cutter width 6,8mm

Dimensions (mm)			
Blade Thickness	S	I	C
1.6	1.8	9	0.05
1.75	2.0, 2.2, 2.5		
2.25	2.5, 2.7, 3.0		
2.7	3.0, 3.2, 3.5		
3.7	4.0, 4.2, 4.5		
4.5	5.0, 5.2, 5.5		

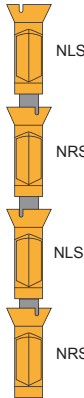
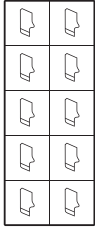
Inserts	Order Code	Grades										
		Carbide					Cermet		Uncoated			
		B100	C200	C250	F20	F30	CE100	CE60	K10		CE	
NLS	LNGT 1818NLS-ME	⊙										 <p>Inserts Sequencing Position</p> <p>(Interleaving one after another different one.)</p>  <p>Inserts 10 PCS / Box</p>
	LNGT 2020NLS-ME	⊙					⊙					
	LNGT 2022NLS-ME	⊙										
	LNGT 2025NLS-ME	⊙										
	LNGT 2525NLS-ME	⊙						⊙				
	LNGT 2527NLS-ME	⊙										
	LNGT 2530NLS-ME	⊙										
	LNGT 3030NLS-ME	⊙						⊙				
	LNGT 3032NLS-ME	⊙										
	LNGT 3035NLS-ME	⊙										
	LNGT 4040NLS-ME	⊙						⊙				
	LNGT 4042NLS-ME	⊙										
	LNGT 4045NLS-ME	⊙										
	LNGT 5050NLS-ME	⊙						⊙				
LNGT 5052NLS-ME	⊙											
LNGT 5055NLS-ME	⊙											
NRS	LNGT 1818NRS-ME	⊙										
	LNGT 2020NRS-ME	⊙					⊙					
	LNGT 2022NRS-ME	⊙										
	LNGT 2025NRS-ME	⊙										
	LNGT 2525NRS-ME	⊙						⊙				
	LNGT 2527NRS-ME	⊙										
	LNGT 2530NRS-ME	⊙										
	LNGT 3030NRS-ME	⊙						⊙				
	LNGT 3032NRS-ME	⊙										
	LNGT 3035NRS-ME	⊙										
	LNGT 4040NRS-ME	⊙						⊙				
	LNGT 4042NRS-ME	⊙										
	LNGT 4045NRS-ME	⊙										
	LNGT 5050NRS-ME	⊙						⊙				
LNGT 5052NRS-ME	⊙											
LNGT 5055NRS-ME	⊙											
NS	LNGT 5050NS-ME	⊙										

- Steel Stainless Steel Steel/Stainless Steel /Super alloy Cast Iron Aluminum Steel/Cast Iron
- Steel/Stainless Steel/Cast Iron
- Prices and stocks are based on present conditions
- Please specify model numbers and the grade of inserts, ie.: LNGT 2020NLS-ME,B100

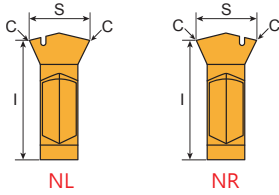

LNGT Inserts



V shape insert designed for superior stability and durability

Tolerances (mm)
S: ±0.02

Dimensions (mm)			
Blade Thickness	S	I	C
1.75	2.0	9	0.05
	2.2		
	2.5		
2.25	2.5		
	2.7		
	3.0		
2.7	3.0		
	3.2		
	3.5		
3.7	4.0		
	4.2		
	4.5		
4.5	5.0		
	5.2		
	5.5		

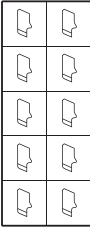
Inserts	Order Code	Grades												
		Carbide					Cermets		Uncoated					
		B100	C200	C250	F20	F30	CE100	CE60	K10	CE				
NL	LNGT 2020NL-M													Inserts Sequencing Position 
	LNGT 2022NL-M													
	LNGT 2025NL-M													
	LNGT 2525NL-M													
	LNGT 2527NL-M													
	LNGT 2530NL-M													
	LNGT 3030NL-M													
	LNGT 3032NL-M													
	LNGT 3035NL-M													
	LNGT 4040NL-M													
	LNGT 4042NL-M													
	LNGT 4045NL-M													
LNGT 5050NL-M														
LNGT 5052NL-M														
LNGT 5055NL-M														
NR	LNGT 2020NR-M													(Interleaving one after another different one.) 
	LNGT 2022NR-M													
	LNGT 2025NR-M													
	LNGT 2525NR-M													
	LNGT 2527NR-M													
	LNGT 2530NR-M													
	LNGT 3030NR-M													
	LNGT 3032NR-M													
	LNGT 3035NR-M													
	LNGT 4040NR-M													
	LNGT 4042NR-M													
	LNGT 4045NR-M													
LNGT 5050NR-M														
LNGT 5052NR-M														
LNGT 5055NR-M														

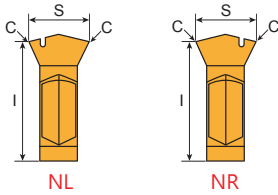

- Steel Stainless Steel Steel/Stainless Steel /Super alloy Cast Iron Aluminum Steel/Cast Iron Steel/Stainless Steel/Cast Iron
- Prices and stocks are based on present conditions
- Please specify model numbers and the grade of inserts, ie.: LNGT 2020NL-M, B100

LNGT Inserts



Tolerances (mm)
S : ±0.02

Dimensions (mm)			
Blade Thickness	S	I	C
1.75	2.0	9	0.05
	2.2		
	2.5		
2.25	2.5		
	2.7		
	3.0		
2.7	3.0		
	3.2		
	3.5		
3.7	4.0		
	4.2		
	4.5		
4.5	5.0		
	5.2		
	5.5		

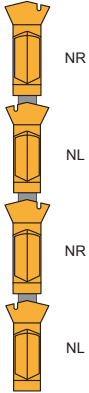
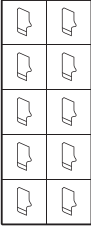
Inserts	Order Code	Grades											
		Carbide				Cermets		Uncoated					
		B100	C200	C250	F20	F30	CE100	CE60	K10		CE		
NL	LNGT 2020NL-ME	⊙											 <p>Inserts Sequencing Position</p>  <p>(Interleaving one after another different one.)</p>  <p>Inserts 10 PCS / Box</p>
	LNGT 2022NL-ME	⊙											
	LNGT 2025NL-ME	⊙											
	LNGT 2525NL-ME	⊙					⊙						
	LNGT 2527NL-ME	⊙											
	LNGT 2530NL-ME	⊙											
	LNGT 3030NL-ME	⊙					⊙						
	LNGT 3032NL-ME	⊙											
	LNGT 3035NL-ME	⊙											
	LNGT 4040NL-ME	⊙					⊙						
	LNGT 4042NL-ME	⊙											
	LNGT 4045NL-ME	⊙											
	LNGT 5050NL-ME	⊙					⊙						
LNGT 5052NL-ME	⊙												
LNGT 5055NL-ME	⊙												
NR	LNGT 2020NR-ME	⊙							⊙				
	LNGT 2022NR-ME	⊙											
	LNGT 2025NR-ME	⊙											
	LNGT 2525NR-ME	⊙							⊙				
	LNGT 2527NR-ME	⊙											
	LNGT 2530NR-ME	⊙											
	LNGT 3030NR-ME	⊙							⊙				
	LNGT 3032NR-ME	⊙											
	LNGT 3035NR-ME	⊙											
	LNGT 4040NR-ME	⊙							⊙				
	LNGT 4042NR-ME	⊙											
	LNGT 4045NR-ME	⊙											
	LNGT 5050NR-ME	⊙							⊙				
LNGT 5052NR-ME	⊙												
LNGT 5055NR-ME	⊙												

- Steel Stainless Steel Steel/Stainless Steel /Super alloy Cast Iron Aluminum Steel/Cast Iron
- Steel/Stainless Steel/Cast Iron
- Prices and stocks are based on present conditions
- Please specify model numbers and the grade of inserts, ie.: LNGT 2020NL-ME,B100

SNGX Inserts

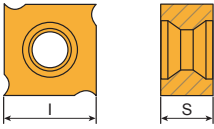

Tolerances (mm)
I=±0.025 S=±0.025

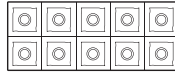

Inserts 10 PCS / Box

Dimensions (mm)		
Cutter Thickness	S	I
1102	2.3	11.0
1103	2.7	
1203	3.2	12.7
1204	4.0	
12045	4.5	
1205	5.4	
1207	7.0	

Inserts	Order Code	Cutting Rate	Grades									
			Carbide					Cermets		Uncoated		
			B100	C200	C250	F20	F30	CE100	CE60	K10	CE	
 E / ME / M	SNGX 1102-E	25 °										
	SNGX 1103-E											
	SNGX 1203-E											
	SNGX 1204-E											
	SNGX 12045-E											
	SNGX 1205-E											
	SNGX 1207-E											
	SNGX 1102-ME	15 °	⊗									
	SNGX 1103-ME		⊗									
	SNGX 1203-ME		⊗									
	SNGX 1204-ME		⊗									
	SNGX 12045-ME		⊗									
	SNGX 1205-ME		⊗									
	SNGX 1207-ME	⊗										
	SNGX 1102T-M	15 °										
	SNGX 1103T-M											
	SNGX 1203T-M											
	SNGX 1204T-M											
	SNGX 12045T-M											
	SNGX 1205T-M											
	SNGX 1207T-M											

- Steel Stainless Steel Steel/Stainless Steel /Super alloy Cast Iron Aluminum Steel/Cast Iron
- Steel/Stainless Steel/Cast Iron
- Prices and stocks are based on present conditions
- Please specify model numbers and the grade of inserts, ie.: SNGX 1102-E,F20

SNGW Inserts

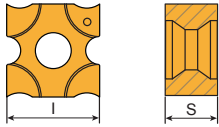

Tolerances (mm)
I=±0.025 S=±0.025

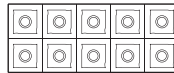

Inserts 10 PCS / Box

Dimensions (mm)		
Cutter Thickness	S	I
1102	2.3	11.0
1103	2.7	
1203	3.2	12.7
1204	4.0	
12045	4.5	
1205	5.4	
1207	7.0	

Inserts	Order Code	Cutting Rake	Grades									
			Carbide					Cermets		Uncoated		
			B100	C200	C250	F20	F30	CE100	CE60	K10	CE	
 E / ME / M	SNGW 1102-E	25°										
	SNGW 1103-E											
	SNGW 1203-E											
	SNGW 1204-E											
	SNGW 12045-E											
	SNGW 1205-E											
	SNGW 1207-E											
	SNGW 1102-ME	15°	⊗									
	SNGW 1103-ME		⊗									
	SNGW 1203-ME		⊗									
	SNGW 1204-ME		⊗									
	SNGW 12045-ME		⊗									
	SNGW 1205-ME		⊗									
	SNGW 1207-ME		⊗									
	SNGW 1102T-M	15°	⊗									
	SNGW 1103T-M		⊗									
	SNGW 1203T-M		⊗									
	SNGW 1204T-M		⊗									
	SNGW 12045T-M		⊗									
	SNGW 1205T-M		⊗									
	SNGW 1207T-M		⊗									

- Steel Stainless Steel Steel/Stainless Steel /Super alloy Cast Iron Aluminum Steel/Cast Iron
- Steel/Stainless Steel/Cast Iron
- Prices and stocks are based on present conditions
- Please specify model numbers and the grade of inserts, ie.: SNGW 1102-E,F20

Insert

SNGW Inserts - R0.4~R3.0

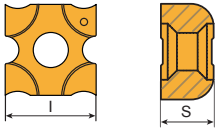

Tolerances (mm)
I=±0.025 S=±0.025

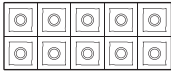

Inserts 10 PCS / Box

Dimensions (mm)				Dimensions (mm)			
Cutter Thickness	S	I	R	Cutter Thickness	S	I	R
1102	2.3	11.0	0.4	12045	4.5	12.7	1.6
1102			0.8	12045			2.0
1103			0.4	1205			0.4
1103	2.7	11.0	0.8	1205	5.4	12.7	0.8
1203			0.4	1205			1.2
1203	3.2	12.7	0.8	1205	7.0	12.7	1.6
1203			1.2	1205			2.0
1204			0.4	1207			2.5
1204	4.0	12.7	0.8	1207	7.0	12.7	0.4
1204			1.2	1207			0.8
1204			1.6	1207			1.2
12045	4.5	12.7	0.4	1207	7.0	12.7	1.6
12045			0.8	1207			2.0
12045			1.2	1207			2.5
				1207			3.0

Inserts	Order Code	Cutting Rake	Grades											
			Carbide					Cermets		Uncoated				
			B100	C200	C250	F20	F30	CE100	CE60	K10	CE			
 ME	SNGW 1102R04-ME	15°	⊗											
	SNGW 1102R08-ME		⊗											
	SNGW 1103R04-ME		⊗											
	SNGW 1103R08-ME		⊗											
	SNGW 1203R04-ME		⊗											
	SNGW 1203R08-ME		⊗											
	SNGW 1203R12-ME		⊗											
	SNGW 1204R04-ME		⊗											
	SNGW 1204R08-ME		⊗											
	SNGW 1204R12-ME		⊗											
	SNGW 1204R16-ME		⊗											
	SNGW 12045R04-ME		⊗											
	SNGW 12045R08-ME		⊗											
	SNGW 12045R12-ME		⊗											
	SNGW 12045R16-ME		⊗											
	SNGW 12045R20-ME		⊗											
	SNGW 1205R04-ME		⊗											
	SNGW 1205R08-ME		⊗											
	SNGW 1205R12-ME		⊗											
	SNGW 1205R16-ME		⊗											
	SNGW 1205R20-ME		⊗											
	SNGW 1205R25-ME		⊗											
	SNGW 1207R04-ME		⊗											
	SNGW 1207R08-ME		⊗											
	SNGW 1207R12-ME		⊗											
	SNGW 1207R16-ME		⊗											
	SNGW 1207R20-ME		⊗											
	SNGW 1207R25-ME		⊗											
	SNGW 1207R30-ME		⊗											

- Steel Stainless Steel Steel/Stainless Steel /Super alloy Cast Iron Aluminum Steel/Cast Iron Steel/Stainless Steel/Cast Iron
- Prices and stocks are based on present conditions
- Please specify model numbers and the grade of inserts, ie.: SNGW 1102R04-ME,F20

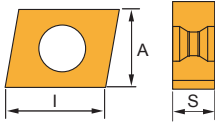

CNGX Inserts



Tolerances (mm)

I=±0.025 S=±0.025 A=±0.025

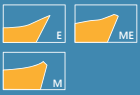
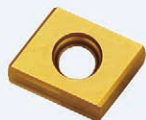
Dimensions (mm)			
Cutter Thickness	S	I	A
1005	5.4	10.0	10
1305		12.7	
1605		16.0	

Inserts	Order Code	Grades									
		Carbide					Cermets		Uncoated		
		B100	C200	C250	F20	F30	CE100	CE60	K10	CE	
	CNGX 1005-E										 Inserts 10 PCS / Box
	CNGX 1305-E										
	CNGX 1605-E										
	CNGX 1005-ME	⊙									
	CNGX 1305-ME	⊙									
	CNGX 1605-ME	⊙									
	CNGX 1005T-M										
	CNGX 1305T-M										
	CNGX 1605T-M										

- Steel
 ■ Stainless Steel
 ⊙ Steel/Stainless Steel /Super alloy
 ■ Cast Iron
 ■ Aluminum
 ■ Steel/Cast Iron
 ⊙ Steel/Stainless Steel/Cast Iron
- Prices and stocks are based on present conditions
- Please specify model numbers and the grade of inserts, ie.: CNGX 1005-E,F20

Recommendation-LNGT Inserts

LNGT Insert Grade Selection

Material group	Recom. fz (mm/tooth)	Inserts			
		LNGT ... M	LNGT...ME	LNGT...EE	
1	0.04-0.12	B100	B100	-	-
2	0.04-0.10	B100	B100	-	-
3	0.04-0.10	B100	B100	-	-
4	0.04-0.10	B100	B100	-	-
5	0.04-0.08	B100	B100	-	-
6	0.04-0.07	B100	B100	-	-
7	0.03-0.06	-	B100	-	-
8	0.04-0.12	-	B100	-	-
9	0.04-0.10	-	B100	-	-
10	0.04-0.09	-	B100	-	-
11	0.04-0.08	-	B100	-	-
12	0.04-0.12	-	F20	-	-
13	0.04-0.12	-	F20	-	-
14	0.04-0.11	-	F20	-	-
15	0.04-0.10	-	F20	-	-
16	0.06-0.13	-	-	F20	-
17	0.06-0.12	-	-	F20	-
18	0.06-0.11	-	-	F20	-
19	0.06-0.09	-	B100	-	-
20	0.06-0.08	-	B100	-	-
21	0.04-0.06	-	B100	-	-
22	0.04-0.07	-	B100	-	-

Insert

Recommendation-LNGT Inserts

• LNGT Insert Recommended Cutting speed, Vc(m/min)

Material group	Grades						
	B100	C250	F20	CE60	CE	K10	F30
	fz (mm/tooth)						
	0.03 0.05 0.08		0.05 0.09 0.13				
Cutting speed, Vc (m/min)							
1	215 195 168	-	-	-	-	-	-
2	168 151 135	-	-	-	-	-	-
3	151 135 122	-	-	-	-	-	-
4	134 122 109	-	-	-	-	-	-
5	121 109 97	-	-	-	-	-	-
6	109 - -	-	-	-	-	-	-
7	- - -	-	-	-	-	-	-
8	160 - 80	-	-	-	-	-	-
9	160 - 80	-	-	-	-	-	-
10	80 - 50	-	-	-	-	-	-
11	80 - 50	-	-	-	-	-	-
12	-	-	168 142 126	-	-	-	-
13	-	-	151 126 117	-	-	-	-
14	-	-	134 117 109	-	-	-	-
15	-	-	105 97 -	-	-	-	-
16	-	-	1150 950 850	-	-	-	-
17	-	-	950 780 700	-	-	-	-
18	-	-	950 780 700	-	-	-	-
19	50 45 -	-	-	-	-	-	-
20	50 45 -	-	-	-	-	-	-
21	35 40 -	-	-	-	-	-	-
22	50 45 -	-	-	-	-	-	-

• Cutting Data-Side Milling

Operations	AR / Dc	Recom.fz (mm/tooth)			Speed Factor
Full engagement	-	0.04	0.08	0.11	0.60
Side Milling	2%	0.17	0.44	0.65	1.10
	5%	0.11	0.28	0.41	1.00
	10%	0.08	0.20	0.30	0.90
	20%	0.07	0.14	0.21	0.85
	30%	0.05	0.12	0.18	0.80
Average Chip Thickness (hm)	-	0.03	0.06	0.09	-

• Type Of Inserts

	Insert Code	Width of slot (mm)
	1414	1.4
	2020	2.0
	2525	2.5
	3030	3.0
	4040	4.0
	5050	5.0

Recommendation-LNGT Inserts

f_z (mm / thoooh)

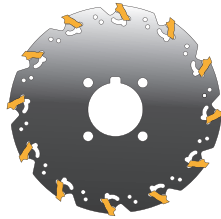

Insert

• f_z (mm/tooth)

AE	f_z (mm/tooth)					
	Material group					
	1 2 3 4	5 6	8 9 10 11	12 13 14 15	16 17 18	19 20 21 22
1.4-1.7 mm	0.02-0.03	0.015-0.025	0.03-0.04	0.02-0.04	0.02-0.04	0.015-0.025
1.8-2.2 mm	0.03-0.05	0.03-0.04	0.03-0.04	0.03-0.06	0.03-0.08	0.02-0.03
2.5-3.0 mm	0.03-0.06	0.03-0.05	0.02-0.03	0.03-0.08	0.03-0.1	0.03-0.04
3.0-3.5 mm	0.04-0.08	0.03-0.06	0.03-0.06	0.04-0.1	0.04-0.1	0.03-0.05
4.0-4.5 mm						
5.0-5.5 mm	0.05-0.1	0.04-0.08	0.04-0.07	0.05-0.12	0.05-0.17	0.04-0.06

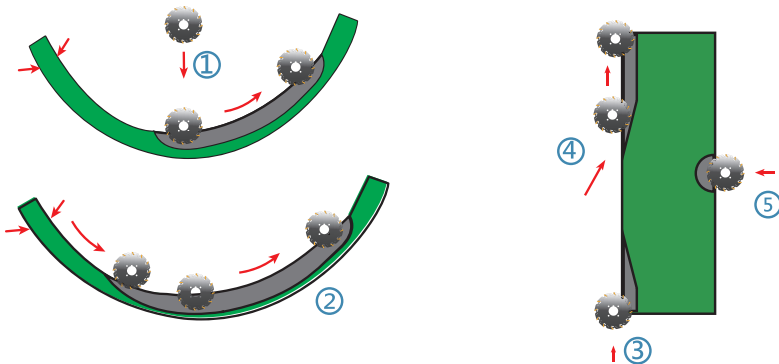

- ① Plunging to mill : F_z reduce to 50%
- ② Ramping to mill : F_z remain 100%
- ③ Mill : F_z remain 100%
- ④ Ramping : F_z remain 100%
- ⑤ Plunging to mill : F_z reduce to 50%

Recommendation-SNGX / SNGW Inserts

• SNGX / SNGW Insert Grade Selection

Material group	Recom. fz (mm/tooth)	Inserts			
		SNGX ... M SNGW ...M	SNGX ... ME SNGW ... ME	SNGX ... EE SNGW ... EE	
1	0.14-0.30	C250/B100	B100	-	-
2	0.14-0.25	C250/B100	B100	-	-
3	0.14-0.22	C250/B100	B100	-	-
4	0.14-0.22	C250/B100	B100	-	-
5	0.14-0.20	C250/B100	B100	-	-
6	0.10-0.15	C250/B100	B100	-	-
7	0.10-0.13	C250/B100	B100	-	-
8	0.14-0.25	-	B100	-	-
9	0.14-0.22	-	B100	-	-
10	0.14-0.20	-	B100	-	-
11	0.10-0.15	-	B100	-	-
12	0.14-0.30	-	F30	-	-
13	0.14-0.22	-	F30	-	-
14	0.14-0.20	-	F30	-	-
15	0.10-0.15	-	F30	-	-
16	0.16-0.30	-	-	F20	-
17	0.16-0.25	-	-	F20	-
18	0.16-0.20	-	-	F20	-
19	0.14-0.20	-	B100	-	-
20	0.14-0.18	-	B100	-	-
21	0.10-0.13	-	B100	-	-
22	0.14-0.20	-	B100	-	-

Recommendation-SNGX SNGW Inserts

• Recommended Cutting Speed, Vc(m/min)

Material group	Grades													
	B100			C250			F20			CE60	CE	K10	F30	
	fz (mm/tooth)													
	0.1	0.2	0.3	0.1	0.2	0.3	0.1	0.2	0.3				0.1	0.2
Cutting Speed, Vc (m/min)														
1	186	166	150	166	146	130	-	-	-	-	-	-	-	-
2	168	150	135	148	130	115	-	-	-	-	-	-	-	-
3	151	136	122	131	116	102	-	-	-	-	-	-	-	-
4	136	122	110	116	102	90	-	-	-	-	-	-	-	-
5	120	110	99	100	90	79	-	-	-	-	-	-	-	-
6	92	78	-	72	58	-	-	-	-	-	-	-	-	-
7	-	-	-	-	-	-	-	-	-	-	-	-	-	-
8	160	-	80	-	-	-	-	-	-	-	-	-	-	-
9	160	-	80	-	-	-	-	-	-	-	-	-	-	-
10	80	-	50	-	-	-	-	-	-	-	-	-	-	-
11	80	-	50	-	-	-	-	-	-	-	-	-	-	-
12	-	-	-	-	-	-	-	-	-	-	-	140	119	105
13	-	-	-	-	-	-	-	-	-	-	-	126	105	98
14	-	-	-	-	-	-	-	-	-	-	-	119	98	91
15	-	-	-	-	-	-	-	-	-	-	-	91	88	-
16	-	-	-	-	-	-	1150	950	850	-	-	-	-	-
17	-	-	-	-	-	-	950	780	700	-	-	-	-	-
18	-	-	-	-	-	-	950	780	700	-	-	-	-	-
19	55	45	-	-	-	-	-	-	-	-	-	-	-	-
20	55	45	-	-	-	-	-	-	-	-	-	-	-	-
21	46	38	-	-	-	-	-	-	-	-	-	-	-	-
22	55	45	-	-	-	-	-	-	-	-	-	-	-	-

Insert

• Cutting Data-Side Milling

Operations	AR / Dc	Recom.fz (mm/tooth)			Speed Factor
Full Engagement	-	0.05	0.10	0.14	0.65
Side Milling	2%	0.21	0.44	0.65	1.20
	5%	0.14	0.28	0.41	1.10
	10%	0.10	0.20	0.30	1.00
	20%	0.07	0.14	0.21	0.90
	30%	0.06	0.12	0.18	0.85
Average Chip Thickness (hm)	-	0.03	0.06	0.09	-

• Type Of Inserts

Insert Code	Width of slot (mm)
1203	6
1204	7
12045	8
1205	10
1207	12



Recommendation-CNGX Inserts

• CNGX Insert Grade Selection

Material group	Recom. fz (mm/tooth)	Inserts			
		CNGX ... M	CNGX...ME	CNGX...E	
1	0.2-0.4	C250/B100	B100	-	-
2		C250/B100	B100	-	-
3	0.2-0.35	C250/B100	B100	-	-
4		C250/B100	B100	-	-
5	0.2-0.32	C250/B100	B100	-	-
6		C250/B100	B100	-	-
7	0.15-0.3	C250/B100	B100	-	-
8	0.2-0.4	-	B100	-	-
9		-	B100	-	-
10	0.2-0.33	-	B100	-	-
11		-	B100	-	-
12	0.22-0.4	-	F30	-	-
13		-	F30	-	-
14	0.2-0.35	-	F30	-	-
15		-	F30	-	-
16	0.22-0.42	-	-	F20	-
17		-	-	F20	-
18		-	-	F20	-
19	0.2-0.3	-	B100	-	-
20		-	B100	-	-
21	0.15-0.25	-	B100	-	-
22	0.2-0.25	-	B100	-	-

• Cutting Data-Side Milling

Operations	AR / Dc	Recom. fz (mm/tooth)			Speed Factor
Full engagement	-	0.05	0.10	0.14	0.65
Side Milling	2%	0.21	0.44	0.65	1.20
	5%	0.14	0.28	0.41	1.10
	10%	0.10	0.20	0.30	1.00
	20%	0.07	0.14	0.21	0.90
	30%	0.06	0.12	0.18	0.85
Average Chip Thickness (hm)	-	0.03	0.06	0.09	-

• Recommended Cutting Speed, Vc(m/min)

Material group	Grades													
	B100		C250		F20		CE60	CE	K10	F30				
	fz (mm/tooth)													
	0.1	0.2	0.3	0.1	0.2	0.3	0.1	0.2	0.3					
Cutting Speed, Vc (m/min)														
1	162	140	123	162	140	123	-	-	-	-	-	-	-	
2	146	123	105	146	123	105	-	-	-	-	-	-	-	
3	120	101	92	120	101	92	-	-	-	-	-	-	-	
4	109	92	84	109	92	84	-	-	-	-	-	-	-	
5	90	78	70	90	78	70	-	-	-	-	-	-	-	
6	63	56	-	64	56	-	-	-	-	-	-	-	-	
7	-	-	-	28	-	-	-	-	-	-	-	-	-	
8	160	-	70	-	-	-	-	-	-	-	-	-	-	
9	160	-	70	-	-	-	-	-	-	-	-	-	-	
10	80	-	50	-	-	-	-	-	-	-	-	-	-	
11	80	-	50	-	-	-	-	-	-	-	-	-	-	
12	-	-	-	-	-	-	-	-	-	-	-	140	119	105
13	-	-	-	-	-	-	-	-	-	-	-	126	105	98
14	-	-	-	-	-	-	-	-	-	-	-	119	98	91
15	-	-	-	-	-	-	-	-	-	-	-	91	84	-
16	-	-	-	-	-	-	805	665	595	-	-	-	-	-
17	-	-	-	-	-	-	665	549	490	-	-	-	-	-
18	-	-	-	-	-	-	-	-	-	-	-	-	-	-
19	40	37	-	-	-	-	-	-	-	-	-	-	-	-
20	40	37	-	-	-	-	-	-	-	-	-	-	-	-
21	35	30	-	-	-	-	-	-	-	-	-	-	-	-
22	40	37	-	-	-	-	-	-	-	-	-	-	-	-

Insert

• Type Of Inserts

	Insert Code	Width of slot (mm)
	1005	14-16
	1305	18-24
	1605	25-30