



Leading Through Innovation



TAPS



TECHNICAL DATA

TECHNISCHE DATEN



TECHNICAL DATA

**SUPER CUTTING TAPS
HOCHLEISTUNGS GEWINDEBOHRER**



TECHNICAL DATA

**SUPER CUTTING TAPS
HOCHLEISTUNGS GEWINDEBOHRER**

**1 TAPS TERMINOLOGY
FACHAUSDRÜCKE BEI GEWINDEBOHRERN (Terminologie)**

**2 RECOMMENDED TAP DRILL SIZE
EMPFOHLENE KERNLOCHMASSE**

Unit : mm

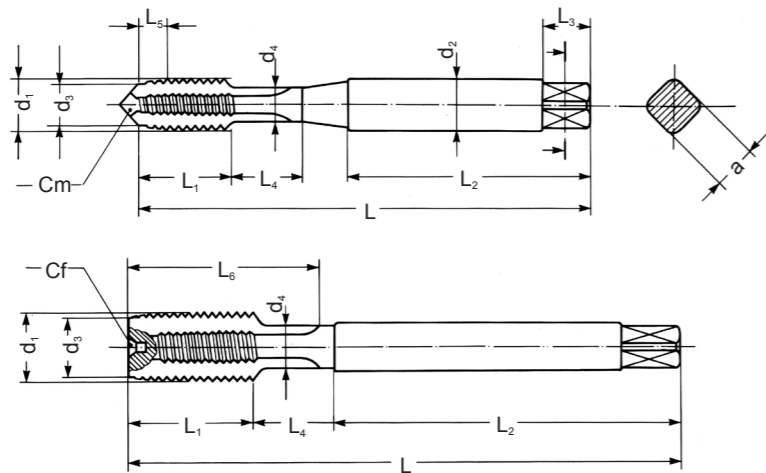

- | | | |
|---------------------------------|---------------------------------------|--|
| d ₁ Major diameter | d ₁ Nenn Aussendurchmesser | d ₁ Diamètre externe nominal |
| d ₂ Shank diameter | d ₂ Schaftdurchmesser | d ₂ Diamètre de la queue |
| d ₃ Chamfer diameter | d ₃ Anschnittdurchmesser | d ₃ Diamètre de l'entrée |
| d ₄ Neck diameter | d ₄ Bunddurchmesser | d ₄ Diamètre de la collerette de dégagement |
| L Total length | L Gesamtlänge | L Longueur totale |
| L ₁ Thread length | L ₁ Gewindelänge | L ₁ Longueur de la partie filetée |
| L ₂ Shank length | L ₂ Schaftlänge | L ₂ Longueur de la queue |
| L ₃ Square length | L ₃ Vierkantlänge | L ₃ Longueur du carré |
| L ₄ Neck length | L ₄ Bundlänge | L ₄ Longueur de la collerette de dégagement |
| L ₅ Chamfer length | L ₅ Anschnittlänge | L ₅ Longueur de l'entrée |
| L ₆ Flutes length | L ₆ Nutenlänge | L ₆ Longueur des goujures |
| a Square | a Vierkantmaß | a Carré |
| Cm Center male | Cm Mittelpunkt des Aussengewindes | Cm Centre mâle |
| Cf Center female | Cf Mittelpunkt des Innengewindes | Cf Centre femelle |

Metric-ISO threads coarse pitch				Metric-ISO threads fine pitch				Metric-ISO threads fine pitch			
M	Pitch	Maximum core dia.	Drill size	MF	Pitch	Maximum core dia.	Drill size	MF	Pitch	Maximum core dia.	Drill size
1	0.25	0.785	0.75	2.5	0.35	2.221	2.15	25	2.00	23.210	23.00
1.1	0.25	0.885	0.85	3	0.35	2.271	2.65	26	1.50	24.676	24.50
1.2	0.25	0.985	0.95	3.5	0.35	3.221	3.15	27	1.00	26.153	26.00
1.4	0.30	1.160	1.10	4	0.50	3.599	3.50	27	1.50	25.676	25.50
1.6	0.35	1.321	1.25	4.5	0.50	4.099	4.00	27	2.00	25.210	25.00
1.7	0.35	1.346	1.30	5	0.50	4.599	4.50	28	1.00	27.153	27.00
1.8	0.35	1.521	1.45	5.5	0.50	5.099	5.00	28	1.50	26.676	26.50
2	0.40	1.679	1.60	6	0.75	5.378	5.20	28	2.00	26.210	26.00
2.2	0.45	1.838	1.75	7	0.75	6.378	6.20	30	1.00	29.153	29.00
2.3	0.40	1.920	1.90	8	0.75	7.378	7.20	30	1.50	28.676	28.50
2.5	0.45	2.138	2.05	8	1.00	7.153	7.00	30	2.00	28.210	28.00
2.6	0.45	2.176	2.10	9	0.75	8.378	8.20	30	3.00	27.252	27.00
3	0.50	2.599	2.50	9	1.00	8.153	8.00	32	1.50	30.675	30.50
3.5	0.60	3.010	2.90	10	0.75	9.378	9.20	32	2.00	30.210	30.00
4	0.70	3.422	3.30	10	1.00	9.153	9.00	33	1.50	31.676	31.50
4.5	0.75	3.878	3.70	10	1.25	8.912	8.80	33	2.00	31.210	31.00
5	0.80	4.334	4.20	11	0.75	10.378	10.20	33	3.00	30.252	30.00
6	1.00	5.153	5.00	11	1.00	10.153	10.00	35	1.50	33.676	33.50
7	1.00	6.153	6.00	12	1.00	11.153	11.00	36	1.50	34.676	34.50
8	1.25	6.912	6.80	12	1.25	10.912	10.80	36	2.00	34.210	34.00
9	1.25	7.912	7.80	12	1.50	10.676	10.50	36	3.00	33.252	33.00
10	1.50	8.676	8.50	14	1.00	13.153	13.00	38	1.50	36.676	36.50
11	1.50	9.676	9.50	14	1.25	12.912	12.80	39	1.50	37.676	37.50
12	1.75	10.441	10.20	14	1.50	12.676	12.50	39	2.00	37.210	37.00
14	2.00	12.210	12.00	15	1.00	14.153	14.00	39	3.00	36.252	36.00
16	2.00	14.210	14.00	15	1.50	13.676	13.50	40	1.50	38.676	38.50
18	2.50	15.744	15.50	16	1.00	15.153	15.00	40	2.00	38.210	38.00
20	2.50	17.744	17.50	16	1.50	14.676	14.50	40	3.00	37.252	37.00
22	2.50	19.744	19.50	17	1.00	16.153	16.00	42	1.50	40.676	40.50
24	3.00	21.252	21.00	17	1.50	15.676	15.50	42	2.00	40.210	40.00
27	3.00	24.252	24.00	18	1.00	17.153	17.00	42	3.00	39.252	39.00
30	3.50	26.771	26.50	18	1.50	16.676	16.50	45	1.50	43.676	43.50
33	3.50	29.771	29.50	18	2.00	16.210	16.00	45	2.00	43.210	43.00
36	4.00	32.270	32.00	20	1.00	19.153	19.00	45	3.00	42.252	42.00
39	4.00	35.270	35.00	20	1.50	18.676	18.50	48	1.50	46.676	46.50
42	4.50	37.799	37.50	20	2.00	18.210	18.00	48	2.00	46.210	46.00
45	4.50	40.799	40.50	22	1.00	21.153	21.00	48	3.00	45.252	45.00
48	5.00	43.297	43.00	22	1.50	20.676	20.50	50	1.50	48.676	48.50
52	5.00	47.297	47.00	22	2.00	20.210	20.00	50	2.00	48.210	48.00
56	5.50	50.796	50.50	24	1.00	23.153	23.00	50	3.00	47.252	47.00
60	5.50	54.796	54.50	24	1.50	22.676	22.50	52	1.50	50.676	50.50
64	6.00	58.305	58.00	24	2.00	22.210	22.00	52	2.00	50.210	50.00
68	6.00	62.305	62.00	25	1.00	24.153	24.00	52	3.00	49.252	49.00
				25	1.50	23.676	23.50				

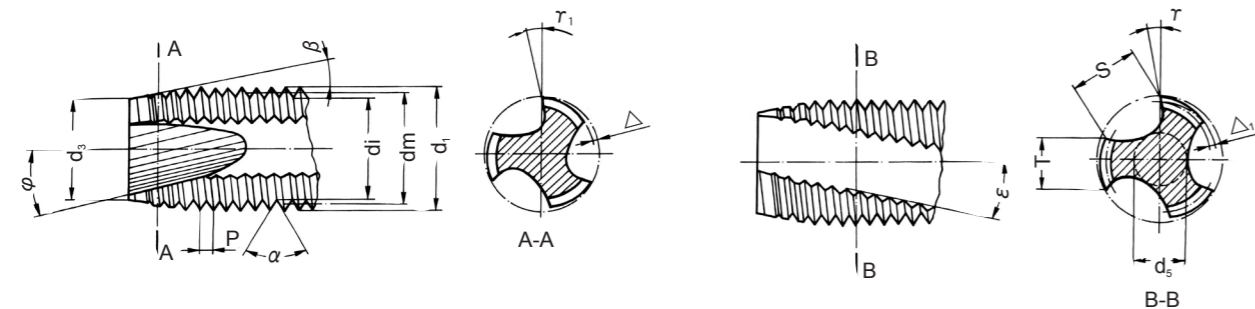

- | | | |
|--|---|---|
| d ₁ Major diameter | d ₁ Nenn Aussendurchmesser | d ₁ Diamètre externe nominal |
| dm Flank diameter | dm Flankendurchmesser | dm Diamètre moyen |
| di Minor diameter | di Kerndurchmesser | di Diamètre interne |
| d ₃ Chamfer diameter | d ₃ Anschnittdurchmesser | d ₃ Diamètre de l'entrée |
| P Pitch | P Steigung | P Pas |
| a Flank angle | a Flankenwinkel | alpha Angle du filet |
| beta Chamfer angle | beta Anschnittwinkel | beta Demi-angle du cône d'entrée |
| phi Gun nose angle | phi Schälsschnittwinkel | phi Angle de l'entrée GUN |
| tau Gun nose rake angle in front | tau Schälsschnitt-Spanwinkel | tau Angle de coupe sur l'entrée GUN |
| T Chamfer relief | T Hinterschiff am Anschnitt | T Détalonnage sur l'entrée |
| Delta ₁ Pitch diameter relief on the land | Delta ₁ Flankenhinterschiff auf Zahnbreite | Delta ₁ Flankenhinterschiff auf Zahnbreite |
| tau Rake angle | tau Spanwinkel | tau Angle de coupe frontale |
| T Width of land | T Zahnstollenbreite | T Largeur des dents |
| S Flute width | S Nutenbreite | S Largeur des goujures |
| d ₅ Web thickness | d ₅ Seelendicke | d ₅ Diamètre de l'âme |
| epsilon Angle of spiral flute | epsilon Spiralwinkel | epsilon Angle d'hélice des goujures |



TECHNICAL DATA

**SUPER CUTTING TAPS
HOCHLEISTUNGS GEWINDEBOHRER**

Unit : mm

American Unified coarse threads				American Unified fine threads			
UNC	TPI	Maximum core dia.	Drill size	UNF	TPI	Maximum core dia.	Drill size
#1	64	1.585	1.50	#0	80	1.306	1.30
#2	56	1.872	1.80	#1	72	1.613	1.60
#3	48	2.146	2.10	#2	64	1.913	1.90
#4	40	2.385	2.30	#3	56	2.197	2.10
#5	40	2.697	2.60	#4	48	2.459	2.40
#6	32	2.896	2.85	#5	44	2.741	2.70
#8	32	3.528	3.50	#6	40	3.012	3.00
#10	24	3.950	3.90	#8	36	3.597	3.50
#12	24	4.590	4.50	#10	32	4.168	4.10
1/4"	20	5.250	5.20	#12	28	4.717	4.70
5/16"	18	6.680	6.60	1/4"	28	5.563	5.50
3/8"	16	8.082	8.00	5/16"	24	6.995	6.90
7/16"	14	9.441	9.40	3/8"	24	8.565	8.50
1/2"	13	10.881	10.75	7/16"	20	9.947	9.90
9/16"	12	12.301	12.25	1/2"	20	11.524	11.50
5/8"	11	13.693	13.50	9/16"	18	12.969	12.90
3/4"	10	16.624	16.50	5/8"	18	14.554	14.50
7/8"	9	19.520	19.50	3/4"	16	17.546	17.50
1"	8	22.344	22.25	7/8"	14	20.493	20.50
1*1/8"	7	25.082	25.00	1"	12	23.363	23.25
1*1/4"	7	28.258	28.25	1*1/8"	12	26.538	26.50
1*3/8"	6	30.851	30.75	1*1/4"	12	29.713	29.50
1*1/2"	6	34.026	34.00	1*3/8"	12	32.888	32.70
1*3/4"	5	39.560	39.50	1*1/2"	12	36.063	36.00
2"	4.5	45.367	45.25				

Whitworth threads B.S.W.				Whitworth pipe thread BSP.PI			
BSW	TPI	Maximum core dia.	Drill size	G(BSP)	TPI	Maximum core dia.	Drill size
3/32"	48	1.910	1.80	1/8"	28	8.848	8.80
1/8"	40	2.590	2.50	1/4"	19	11.890	11.80
5/32"	32	3.211	3.10	3/8"	19	15.395	15.25
3/16"	24	3.743	3.60	1/2"	14	19.172	19.00
7/32"	24	4.538	4.40	5/8"	14	21.128	21.00
1/4"	20	5.224	5.10	3/4"	14	24.658	24.50
5/16"	18	6.661	6.50	7/8"	14	28.418	28.25
3/8"	16	8.052	7.90	1"	11	30.931	30.75
7/16"	14	9.379	9.30	1*1/8"	11	35.579	35.50
1/2"	12	10.610	10.50	1*1/4"	11	39.592	39.50
9/16"	12	12.176	12.00	1*3/8"	11	42.005	42.00
5/8"	11	13.598	13.50	1*1/2"	11	45.485	45.20
3/4"	10	16.538	16.50	1*5/8"	11	49.670	49.60
7/8"	9	19.411	19.25	1*3/4"	11	51.428	51.40
1"	8	22.185	22.00	2"	11	57.296	57.20
1*1/8"	7	24.879	24.75	2*1/4"	11	63.392	63.30
1*1/4"	7	28.054	27.75	2*3/8"	11	67.080	67.00
1*3/8"	6	30.555	30.50	2*1/2"	11	72.866	72.80
1*1/2"	6	33.730	33.50	2*3/4"	11	79.216	79.10
1*5/8"	5	35.921	35.50	3"	11	85.566	85.50
1*3/4"	5	39.096	39.00	3*1/4"	11	91.662	91.50
1*7/8"	4.5	41.648	41.50	3*1/2"	11	98.012	98.00
2"	4.5	44.823	44.50	3*3/4"	11	104.362	104.00
2*1/4"	4	50.420	50.00	4"	11	110.712	110.50
2*1/2"	4	56.770	56.50				
2*3/4"	3.5	62.108	62.00				
3"	3.5	68.459	68.50				



TECHNICAL DATA

**SUPER CUTTING TAPS
HOCHLEISTUNGS GEWINDEBOHRER**

**3 TAP TOLERANCES
GEWINDEBOHRER TOLERANZEN**

Tolerance classes of taps and tolerance positions for screw threads as per Metric ISO Standard.
Toleranzklassen und Toleranzfelder für Schraubengewinde entsprechen dem metrischen ISO-Standard

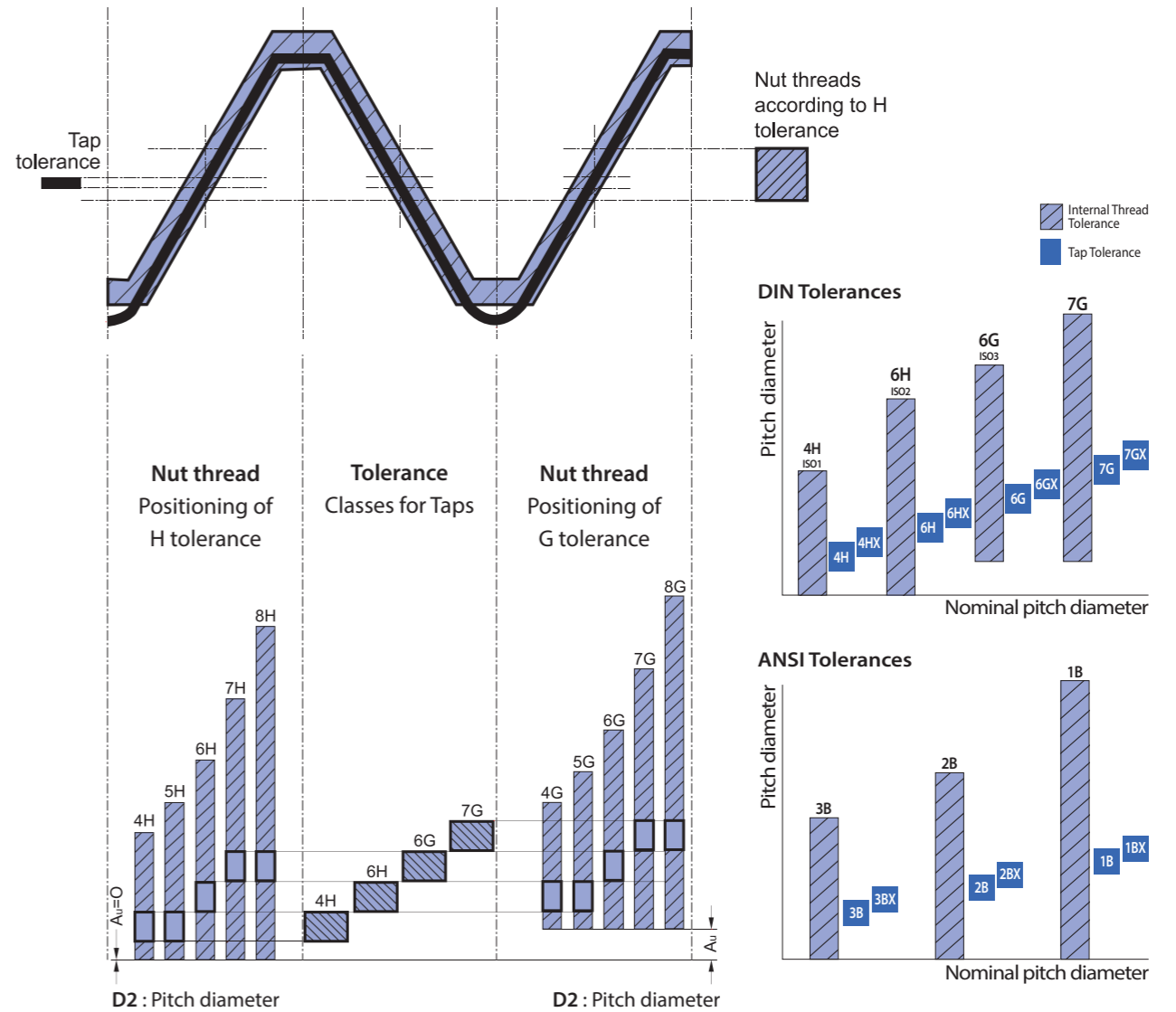

► Taps tolerances and recommended classes

Tap tolerance ISO	Tap tolerance DIN	Correct class to obtain Nut thread with tolerance			
ISO 1	4H	4H	5H		
ISO 2	6H	4G	5G	6H	
ISO 3	6G			6G	7H
	7G				7G
					8H
					8G



**METRIC ISO COARSE THREADS
METRISCHES ISO-GEWINDE**

Nominal dimensions UNI 4535-64
Production tolerances on tap pitch diameter for ISO 6H Nut threads
Limit dimensions-Nut threads ISO 6H

Dimensions in mm
 $H = 0.86603P$
 $H_1 = \frac{5}{8} H = 0.54127P$
 $h_3 = \frac{17}{24} H = 0.61343P$
 $d_2 = D_2 = d - H = \frac{3}{4} d - 0.64952P$
 $d_3 = d - 2h_3 = d - 1.22687P$
 $r = \frac{H}{6} = 0.14434P$

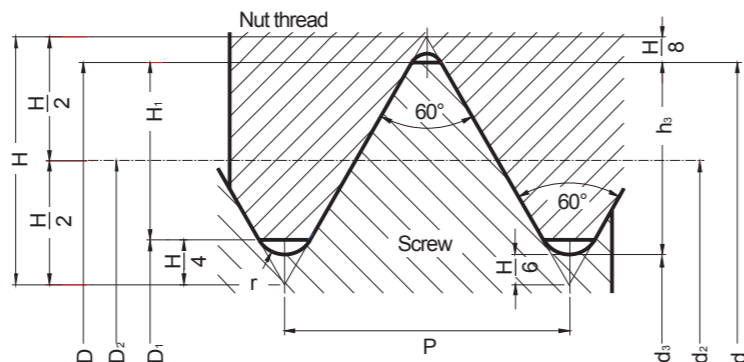

Nominal diameter d = D	Pitch P	Pitch diameter d2 = D2	Minor diameter		Thread depth		Radius r	Pitch diameter Tap tolerance 6H		Pitch diameter Nut tolerance 6H	
			Screw d3	Nut D1	Screw h3	Nut H1		d2		d2	
M 1.6	0.35	1.373	1.171	1.221	0.215	0.189	0.051	1.393	1.407	1.373	1.458
M 1.8	0.35	1.573	1.371	1.421	0.215	0.189	0.051	1.593	1.607	1.573	1.658
M 2	0.4	1.740	1.509	1.567	0.245	0.217	0.058	1.761	1.776	1.740	1.830
M 2.2	0.45	1.908	1.648	1.713	0.276	0.244	0.065	1.931	1.946	1.908	2.003
M 2.5	0.45	2.208	1.948	2.013	0.276	0.244	0.065	2.231	2.246	2.208	2.303
M 3	0.5	2.675	2.387	2.459	0.307	0.271	0.072	2.699	2.715	2.675	2.775
M 3.5	0.6	3.110	2.764	2.850	0.368	0.325	0.087	3.137	3.155	3.110	3.222
M 4	0.7	3.545	3.141	3.242	0.429	0.379	0.101	3.574	3.593	3.545	3.663
M 4.5	0.75	4.013	3.580	3.688	0.460	0.406	0.108	4.042	4.061	4.013	4.131
M 5	0.8	4.480	4.019	4.134	0.491	0.433	0.115	4.510	4.530	4.480	4.605
M 6	1	5.350	4.773	4.917	0.613	0.541	0.144	5.385	5.409	5.350	5.500
M 7	1	6.350	5.773	5.917	0.613	0.541	0.144	6.385	6.409	6.350	6.500
M 8	1.25	7.188	6.466	6.647	0.767	0.677	0.180	7.226	7.251	7.188	7.348
M 9	1.25	8.188	7.466	7.647	0.767	0.677	0.180	8.226	8.251	8.188	8.348
M 10	1.5	9.026	8.160	8.376	0.920	0.812	0.217	9.068	9.096	9.026	9.206
M 11	1.5	10.026	9.160	9.376	0.920	0.812	0.217	10.068	10.096	10.026	10.206
M 12	1.75	10.863	9.853	10.106	1.074	0.947	0.253	10.911	10.943	10.863	11.063
M 14	2	12.701	11.546	11.835	1.227	1.083	0.289	12.752	12.786	12.701	12.913
M 16	2	14.701	13.546	13.835	1.227	1.083	0.289	14.752	14.786	14.701	14.913
M 18	2.5	16.376	14.933	15.294	1.534	1.353	0.361	16.430	16.466	16.376	16.600
M 20	2.5	18.376	16.933	17.294	1.534	1.353	0.361	18.430	18.466	18.376	18.600
M 22	2.5	20.376	18.933	19.294	1.534	1.353	0.361	20.430	20.466	20.376	20.600
M 24	3	22.051	20.319	20.752	1.840	1.624	0.433	22.115	22.157	22.051	22.316
M 27	3	25.051	23.319	23.752	1.840	1.624	0.433	25.115	25.157	25.051	25.316
M 30	3.5	27.727	25.706	26.211	2.147	1.894	0.505	27.794	27.839	27.727	28.007
M 33	3.5	30.727	28.706	29.211	2.147	1.894	0.505	30.794	30.839	30.727	31.007
M 36	4	33.402	31.093	31.670	2.454	2.165	0.577	33.473	33.520	33.402	33.702
M 39	4	36.402	34.093	34.670	2.454	2.165	0.577	36.473	36.520	36.402	36.702
M 42	4.5	39.077	36.479	37.129	2.760	2.436	0.650	39.152	39.202	39.077	39.392
M 45	4.5	42.077	39.479	40.129	2.760	2.436	0.650	42.152	42.202	42.077	42.392
M 48	5	44.752	41.866	42.587	3.067	2.706	0.722	44.832	44.885	44.752	45.087
M 52	5	48.752	45.866	46.587	3.067	2.706	0.722	48.832	48.885	48.752	49.087
M 56	5.5	52.428	49.252	50.046	3.374	2.977	0.794	52.512	52.568	52.428	52.783
M 60	5.5	56.428	53.252	54.046	3.374	2.977	0.794	56.512	56.568	56.428	56.783
M 64	6	60.103	56.639	57.505	3.681	3.248	0.866	60.193	60.253	60.103	60.478
M 68	6	64.103	60.639	61.505	3.681	3.248	0.866	64.193	64.253	64.103	64.478

Metric thread MA(old UNI 159 Profile) Nut tolerance SH8

M 1.7	0.35	1.473	1.246	1.246	0.227	0.227	0.040	1.493	1.507	1.473	1.529
M 2.3	0.4	2.040	1.780	1.780	0.260	0.260	0.040	2.061	2.076	2.040	2.120
M 2.6	0.45	2.308	2.016	2.016	0.292	0.292	0.050	2.331	2.346	2.308	2.388

**METRIC ISO FINE THREADS
METRISCHES ISO-FEINGEWINDE**

Nominal dimensions UNI 4535-64
Production tolerances on tap flank diameter for ISO 6H Nut threads
Limit dimensions-Nut threads ISO 6H

Dimensions in mm
 $H = 0.86603P$
 $H_1 = \frac{5}{8} H = 0.54127P$
 $h_3 = \frac{17}{24} H = 0.61343P$
 $d_2 = D_2 = d - \frac{3}{4} H = d - 0.64952P$
 $d_3 = d - 2h_3 = d - 1.22687P$
 $r = \frac{H}{6} = 0.14434P$

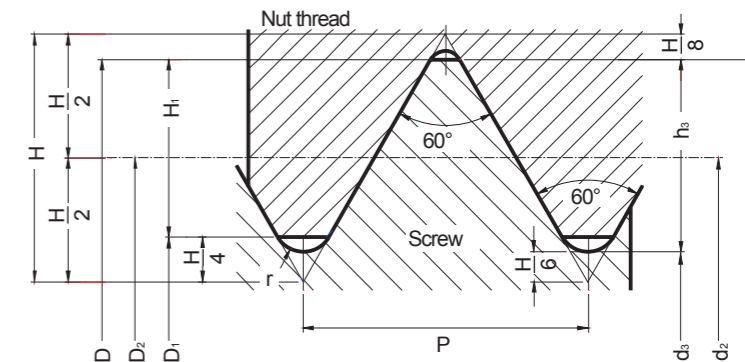

Nominal diameter d = D	Pitch P	Pitch diameter d2 = D2	Minor diameter		Thread depth		Radius r	Pitch diameter Tap tolerance 6H		Pitch diameter Nut tolerance 6H	
			Screw d3	Nut D1	Screw h3	Nut H1		d2		d2	
M 2	0.25	1.838	1.693	1.729	0.153	0.135	0.036	1.844	1.856	1.838	1.886
M 2.5	0.35	2.273	2.701	2.121	0.215	0.189	0.051	2.293	2.307	2.273	2.358
M 3	0.35	2.773	2.571	2.621	0.215	0.189	0.051	2.794	2.809	2.773	2.863
M 3.5	0.35	3.273	3.071	3.121	0.215	0.189	0.051	3.294	3.309	3.273	3.363
M 4	0.5	3.675	3.387	3.459	0.307	0.271	0.072	3.699	3.715	3.675	3.775
M 4.5	0.5	4.175	3.887	3.959	0.307	0.271	0.072	4.199	4.215	4.175	4.275
M 5	0.5	4.675	4.387	4.459	0.307	0.271	0.072	4.699	4.715	4.675	4.775
M 5.5	0.5	5.175	4.887	4.959	0.307	0.271	0.072	5.199	5.215	5.175	5.275
M 6	0.5	5.675	5.387	5.459	0.307	0.271	0.072	5.702	5.720	5.675	5.787
M 6	0.75	5.513	5.080	5.188	0.460	0.406	0.108	5.545	5.566	5.513	5.645
M 7	0.75	6.513	6.080	6.188	0.460	0.406	0.108	6.545	6.566	6.513	6.645
M 8	0.5	7.675	7.387	7.459	0.307	0.271	0.072	7.702	7.720	7.675	7.787
M 8	0.75	7.513	7.080	7.188	0.460	0.406	0.108	7.545	7.566	7.513	7.645
M 8	1	7.350	6.773	6.917	0.613	0.541	0.144	7.835	7.409	7.350	7.500
M 9	0.75	8.513	8.080	8.188	0.460	0.406	0.108	8.545	8.566	8.513	8.645
M 9	1	8.350	7.773	7.917	0.613	0.541	0.144	8.385	8.409	8.350	8.500
M 10	0.5	9.675	9.387	9.459	0.307	0.271	0.072	9.702	9.720	9.675	9.787
M 10	0.75	9.513	9.080	9.188	0.460	0.406	0.108	9.545	9.566	9.513	9.645
M 10	1	9.350	8.773	8.917	0.613	0.541	0.144	9.385	9.409	9.350	9.500
M 10	1.25	9.188	8.466	8.647	0.767	0.677	0.180	9.226	9.251	9.188	9.348
M 11	0.75	10.513	10.080	10.188	0.460	0.406	0.108	10.545	10.566	10.513	10.645
M 11	1	10.350	9.773	9.917	0.613	0.541	0.144	10.385	10.409	10.350	10.500
M 12	0.75	11.513	11.080	11.188	0.460	0.406	0.108	11.547	11.569	11.513	11.653
M 12	1	11.350	10.773	10.917	0.613	0.541	0.144	11.388	11.413	11.350	11.510
M 12	1.25	11.188	10.466	10.647	0.767	0.677	0.180	11.230	11.258	11.188	11.368
M 12	1.5	11.026	10.160	10.376	0.920	0.812	0.217	11.071	11.101	11.026	11.216
M 13	1	12.350	11.773	11.917	0.613	0.541	0.144	12.388	12.413	12.350	12.510
M 14	1	13.350	12.773	12.917	0.613	0.541	0.144	13.388	13.413	13.350	13.510
M 14	1.25	13.188	12.466	12.647	0.767	0.677	0.180	13.230	13.258	13.188	13.368
M 14	1.5	13.026	12.160	12.376	0.920	0.812	0.217	13.071	13.101	13.026	13.216
M 15	1	14.350	13.773	13.917	0.613	0.541	0.144	14.388	14.413	14.350	14.510
M 15	1.5	14.026	13.160	13.376	0.920	0.812	0.217	14.071	14.101	14.026	14.216
M 16	1	15.350	14.773	14.917	0.613	0.541	0.144	15.388	15.413	15.350	15.510
M 16	1.25	15.188	14.466	14.647	0.767	0.677	0.180	15.230	15.258	15.188	15.368
M 16	1.5	15.026	14.160	14.376	0.920	0.812	0.217	15.071	15.101	15.026	15.216
M 17	1	16.350	15.773	15.917	0.613	0.541	0.144	16.388	16.413	16.350	16.510
M 17	1.5	16.026	15.160	15.376	0.920	0.812	0.217	16.071	16.101	16.026	16.216
M 18	1	17.350	16.773	16.917	0.613	0.541	0.144	17.388	17.413	17.350	17.510
M 18	1.5	17.026	16.160	16.376	0.920	0.812	0.217	17.071	17.101	17.026	17.216
M 1											



Nominal diameter	Pitch	Pitch diameter d ₂ = D ₂	Minor diameter		Thread depth		Radius r	Pitch diameter Tap tolerance 6H		Pitch diameter Nut tolerance 6H	
			Screw d ₃	Nut D ₁	Screw h ₃	Nut H ₁		min.	max.	min.	max.
M 22	2	20.701	19.546	19.835	1.227	1.083	0.289	20.752	20.786	20.701	20.913
M 24	1	23.350	22.773	22.917	0.613	0.541	0.144	23.390	23.416	23.350	23.520
M 24	1.5	23.026	22.160	22.376	0.920	0.812	0.217	23.074	23.106	23.026	23.226
M 24	2	22.701	21.546	21.835	1.227	1.083	0.289	22.754	22.791	22.701	22.925
M 25	1	24.350	23.773	23.917	0.613	0.541	0.144	24.390	24.416	24.350	24.520
M 25	1.5	24.026	23.160	23.376	0.920	0.812	0.217	24.074	24.106	24.026	24.226
M 25	2	23.701	22.546	22.835	1.227	1.083	0.289	23.754	23.791	23.701	23.925
M 26	1	25.350	24.773	24.917	0.613	0.541	0.144	25.390	25.416	25.350	25.520
M 26	1.5	25.026	24.160	24.376	0.920	0.812	0.217	25.074	25.106	25.026	25.226
M 26	2	24.701	23.546	23.835	1.227	1.083	0.289	24.754	24.791	24.701	24.925
M 27	1	26.350	25.773	25.917	0.613	0.541	0.144	26.390	26.416	26.350	26.520
M 27	1.5	26.026	25.160	25.376	0.920	0.812	0.217	26.074	26.106	26.026	26.226
M 27	2	25.701	24.546	24.835	1.227	1.083	0.289	25.754	25.791	25.701	25.925
M 28	1	27.350	26.773	26.917	0.613	0.541	0.144	27.390	27.416	27.350	27.520
M 28	1.5	27.026	26.160	26.376	0.920	0.812	0.217	27.074	27.106	27.026	27.226
M 28	2	26.701	25.546	25.835	1.227	1.083	0.289	26.754	26.791	26.701	26.925
M 30	1	29.350	28.773	28.917	0.613	0.541	0.144	29.390	29.416	29.350	29.520
M 30	1.5	29.026	28.160	28.376	0.920	0.812	0.217	29.074	29.106	29.026	29.226
M 30	2	28.701	27.546	27.835	1.227	1.083	0.289	28.754	28.791	28.701	28.925
M 30	3	28.051	26.319	26.752	1.840	1.624	0.433	28.115	28.157	28.051	28.316
M 32	1.5	31.026	30.160	30.376	0.920	0.812	0.217	31.074	31.106	31.026	31.226
M 32	2	30.701	29.546	29.835	1.227	1.083	0.289	30.754	30.791	30.701	30.925
M 33	1.5	32.026	31.160	31.376	0.920	0.812	0.217	32.074	32.106	32.026	32.226
M 33	2	31.701	30.546	30.835	1.227	1.083	0.289	31.754	31.791	31.701	31.925
M 33	3	31.051	29.319	29.752	1.840	1.624	0.433	31.115	31.157	31.051	31.316
M 35	1.5	34.026	33.160	33.376	0.920	0.812	0.217	34.074	34.106	34.026	34.226
M 35	2	33.701	32.546	32.835	1.227	1.083	0.289	33.754	33.791	33.701	33.925
M 36	1.5	35.026	34.160	34.376	0.920	0.812	0.217	35.074	35.106	35.026	35.226
M 36	2	34.701	33.546	33.835	1.227	1.083	0.289	34.754	34.791	34.701	34.925
M 36	3	34.051	32.319	32.752	1.840	1.624	0.433	34.115	34.157	34.051	34.316
M 38	1.5	37.026	36.160	36.376	0.920	0.812	0.217	37.074	37.106	37.026	37.226
M 39	1.5	38.026	37.160	37.376	0.920	0.812	0.217	38.074	38.106	38.026	38.226
M 39	2	37.701	36.546	36.835	1.227	1.083	0.289	37.754	37.791	37.701	37.925
M 39	3	37.051	35.319	35.752	1.840	1.624	0.433	37.115	37.157	37.051	37.316
M 40	1.5	39.026	38.160	38.376	0.920	0.812	0.217	39.074	39.106	39.026	39.226
M 40	2	38.701	37.546	37.835	1.227	1.083	0.289	38.754	38.791	38.701	38.925
M 40	3	38.051	36.319	36.752	1.840	1.624	0.433	38.115	38.157	38.051	38.316
M 42	1.5	41.026	40.160	40.376	0.920	0.812	0.217	41.074	41.106	41.026	41.226
M 42	2	40.701	39.546	39.835	1.227	1.083	0.289	40.754	40.791	40.701	40.925
M 42	3	40.051	38.319	38.752	1.840	1.624	0.433	40.115	40.157	40.051	40.316
M 45	1.5	44.026	43.160	43.376	0.920	0.812	0.217	44.074	44.106	44.026	44.226
M 45	2	43.701	42.546	42.835	1.227	1.083	0.289	43.754	43.791	43.701	43.925
M 45	3	43.051	41.319	41.752	1.840	1.624	0.433	43.115	43.157	43.051	43.316
M 48	1.5	47.026	46.160	46.376	0.920	0.812	0.217	47.074	47.106	47.026	47.226
M 48	2	46.701	45.546	45.835	1.227	1.083	0.289	46.754	46.796	46.701	46.937
M 48	3	46.051	44.319	44.752	1.840	1.624	0.433	46.115	46.157	46.051	46.316
M 50	1.5	49.026	48.160	48.376	0.920	0.812	0.217	49.074	49.106	49.026	49.226
M 50	2	48.701	47.546	47.835	1.227	1.083	0.289	48.754	48.796	48.701	48.937
M 50	3	48.051	46.319	46.752	1.840	1.624	0.433	48.115	48.157	48.051	48.316
M 52	1.5	51.026	50.160	50.376	0.920	0.812	0.217	51.074	51.106	51.026	51.226
M 52	2	50.701	49.546	49.835	1.227	1.083	0.289	50.754	50.796	50.701	50.937
M 52	3	50.051	48.319	48.752	1.840	1.624	0.433	50.115	50.157	50.051	50.316
M 55	1.5	54.026	53.160	53.376	0.920	0.812	0.217	54.074	54.106	54.026	54.226
M 55	2	53.701	52.546	52.835	1.227	1.083	0.289	53.754	53.796	53.701	53.937
M 55	3	53.051	51.319	51.752	1.840	1.624	0.433	53.115	53.157	53.051	53.316
M 56	1.5	55.026	54.160	54.376	0.920	0.812	0.217	55.074	55.106	55.026	55.226
M 56	2	54.701	53.546	53.835	1.227	1.083	0.289	54.754	54.796	54.701	54.937
M 56	3	54.051	52.319	52.752	1.840	1.624	0.433	54.115	54.157	54.051	54.316
M 58	1.5	57.026	56.160	56.376	0.920	0.812	0.217	57.074	57.106	57.026	57.226
M 58	2	56.701	55.546	55.835	1.227	1.083	0.289	56.754	56.796	56.701	56.937
M 58	3	56.051	54.319	54.752	1.840	1.624	0.433	56.115	56.157	56.051	56.316
M 60	1.5	59.026	58.160	58.376	0.920	0.812	0.217	59.074	59.106	59.026	59.226
M 60	2	58.701	57.546	57.835	1.227	1.083	0.289	58.754	58.796	58.701	58.937
M 60	3	58.051	56.319	56.752	1.840	1.624	0.433	58.115	58.157	58.051	58.316

Metric thread MB(old UNI 160 Profile)						Nut tolerance SH8					
M 2,3	0.25	2.138	1.976	1.976	0.162	0.162	0.030	2.144	2.156	2.138	2.194
M 2,6	0.35	2.373	2.146	2.146	0.227	0.227	0.040	2.393	2.407	2.373	2.429



**UNIFIED COARSE THREADS
UNIFIED GROBGEWINDE**

Nominal dimensions as per ANSI B1.1
Production tolerances on tap flank diameter for 2B class nut threads
Limit dimensions-Nut threads as per ANSI B1.1, 2B-3B tolerance classes

Dimensions in mm
 $H = 0.86603P$
 $H_1 = \frac{5}{8}H = 0.54127P$
 $h_3 = \frac{17}{24}H = 0.61343P$
 $d_2 = D_2 = d - \frac{3}{4}H = d - 0.64952P$
 $d_3 = d - 2h_3 = d - 1.22687P$
 $r = \frac{H}{6} = 0.14434P$

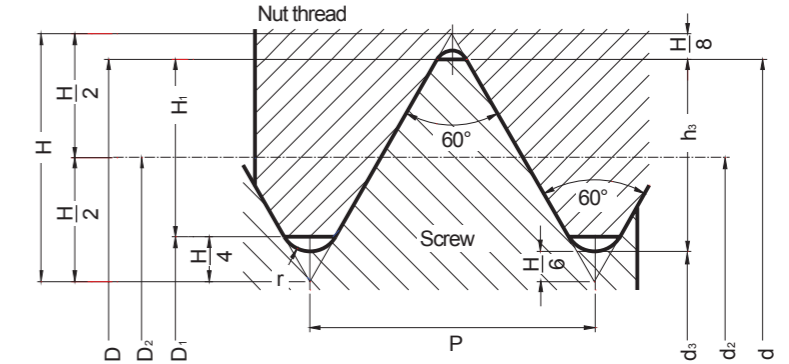

Nominal diameter	TPI	Pitch P	External diameter d = D	Flank diameter d ₂ = D ₂	Thread depth		Flank diameter Tap tolerance 2B		Flank diameter Nut tolerance		
					Nut D ₁	Screw d ₃	min.	max.	min. 2B/3B	max. 2B	max. 3B
#1	- 64 UNC	0.397	1.854	1.598	1.425	1.367	1.610	1.623	1.598	1.664	1.646
#2	- 64 UNC	0.454	2.184	1.890	1.694	1.628	1.902	1.915	1.890	1.961	1.943
#3	- 48 UNC	0.529	2.515	2.172	1.941	1.864	2.184	2.197	2.172	2.248	2.228
#4	- 40 UNC	0.635	2.845	2.433	2.156	2.065	2.446	2.459	2.433	2.517	2.494
#5	- 40 UNC	0.635	3.175	2.764	2.487	2.395	2.776	2.789	2.764	2.847	2.827
#6	- 32 UNC	0.794	3.505	2.990	2.647	2.532	3.105	3.028	2.990	3.084	3.058
#8	- 32 UNC	0.794	4.166	3.650	3.307	3.193	3.675	3.688	3.650	3.746	3.721
#10	- 24 UNC	1.058	4.826	4.138	3.680	3.528	4.163	4.176	4.138	4.247	4.219
#12	- 24 UNC	1.058	5.486	4.798	4.341	4.188	4.823	4.836	4.798	4.910	4.882
1/4"	- 20 UNC	1.270	6.350	5.524	4.976	4.793	5.575	5.588	5.524	5.646	5.616
5/16"	- 18 UNC	1.411	7.938	7.021	6.411	6.205	7.071	7.084	7.021	7.155	7.120
3/8"	- 16 UNC	1.588	9.525	8.494	7.805	7.577	8.545	8.557	8.494	8.639	8.603
7/16"	- 14 UNC	1.814	11.112	9.934	9.149	8.887	9.985	9.997	9.934	10.089	10.051
1/2"	- 13 UNC	1.954	12.700	11.430	10.584	10.302	11.481	11.494	11.430	11.595	11.552
9/16"	- 12 UNC	2.117	14.288	12.913	11.996	11.692	12.964	12.977	12.913	13.086	13.043
5/8"	- 11 UNC	2.309	15.875	14.376	13.376	13.043	14.427	14.440	14.376	14.559	14.514
3/4"	- 10 UNC	2.540	19.050	17.399	16.229	15.933	17.450	17.463	17.399	17.595	17.544
7/8"	- 9 UNC	2.822	22.225	20.391	19.169	18.763	20.455	20.467	20.391	20.599	20.546
1"	- 8 UNC	3.175	25.400	23.338	21.963	21.504	23.401	23.414	23.338	23.561	23.505
1*1/8"	- 7 UNC	3.629	28.575	26.218	24.648	24.122					



**UNIFIED FINE THREADS
UNIFIED FEINGEWINDE**

Nominal dimensions as per ANSI B1.1
Production tolerances on tap flank diameter for 2B class nut threads
Limit dimensions-Nut threads as per ANSI B1.1, 2B-3B tolerance classes

Dimensions in mm

$H = 0.86603P$

$H_1 = \frac{5}{8} H = 0.54127P$

$h_3 = \frac{17}{24} H = 0.61343P$

$d_2 = D_2 = d - \frac{3}{4} H = d - 0.64952P$

$d_3 = d - 2h_3 = d - 1.22687P$

$r = \frac{H}{6} = 0.14434P$

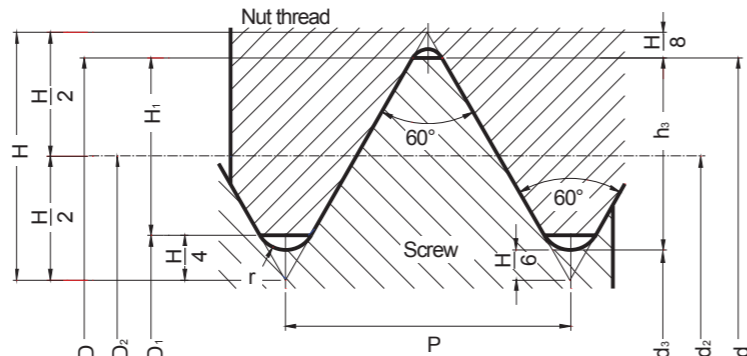

Nominal diameter	TPI	Pitch	External diameter d = D	Flank diameter d2 = D2	Thread depth		Flank diameter Tap tolerance 2B		Flank diameter Nut tolerance		
					Nut D1	Screw d3	min.	max.	min. 2B/3B	max. 2B	max. 3B
#0	-80 UNF	0.318	1.524	1.318	1.181	1.135	1.331	1.344	1.318	1.377	1.361
#1	-72 UNF	0.353	1.854	1.626	1.473	1.422	1.638	1.651	1.626	1.689	1.674
#2	-64 UNF	0.397	2.184	1.928	1.755	1.697	1.941	1.953	1.928	1.996	1.979
#3	-56 UNF	0.454	2.515	2.220	2.024	1.958	2.233	2.245	2.220	2.291	2.273
#4	-48 UNF	0.529	2.845	2.502	2.271	2.195	2.515	2.527	2.502	2.581	2.560
#5	-44 UNF	0.577	3.175	2.799	2.550	2.466	2.812	2.824	2.799	2.880	2.860
#6	-40 UNF	0.635	3.505	3.094	2.817	2.725	3.108	3.119	3.094	3.180	3.157
#8	-36 UNF	0.706	4.166	3.708	3.401	3.299	3.721	3.734	3.708	3.800	3.777
#10	-32 UNF	0.794	4.826	4.310	3.967	3.853	4.336	4.348	4.310	4.409	4.384
#12	-28 UNF	0.907	5.486	4.897	4.503	4.374	4.923	4.935	4.897	5.004	4.976
1/4"	-28 UNF	0.907	6.350	5.761	5.367	5.237	5.799	5.812	5.761	5.870	5.842
5/16"	-24 UNF	1.058	7.938	7.249	6.792	6.640	7.287	7.300	7.249	7.371	7.341
3/8"	-24 UNF	1.058	9.525	8.837	8.379	8.227	8.875	8.887	8.837	8.961	8.931
7/16"	-20 UNF	1.270	11.112	10.287	9.738	9.555	10.338	10.351	10.287	10.424	10.391
1/2"	-20 UNF	1.270	12.700	11.874	11.326	11.143	11.925	11.938	11.874	12.017	11.981
9/16"	-18 UNF	1.411	14.288	13.371	12.761	12.555	13.421	13.434	13.371	13.520	13.482
5/8"	-18 UNF	1.411	15.875	14.958	14.348	14.143	15.009	15.022	14.958	15.110	15.072
3/4"	-16 UNF	1.588	19.050	18.019	17.330	17.102	18.070	18.082	18.019	18.184	18.143
7/8"	-14 UNF	1.814	22.225	21.046	20.262	20.000	21.110	21.123	21.046	21.224	21.181
1"	-12 UNF	2.117	25.400	24.026	23.109	22.804	24.089	24.102	24.026	24.219	24.171
1 1/8"	-12 UNF	2.117	28.575	27.201	26.284	25.979	27.252	27.277	27.201	27.339	27.351
1 1/4"	-12 UNF	2.117	31.750	30.376	29.459	29.154	30.427	30.452	30.376	30.579	30.528
1 3/8"	-12 UNF	2.117	34.925	33.551	32.634	32.329	33.602	33.627	33.551	33.759	33.706
1 1/2"	-12 UNF	2.117	38.100	36.726	35.809	35.504	36.777	36.802	36.726	36.937	36.886

**WHITWORTH PIPE THREADS
WHITWORTH ROHRGEWINDE**

Nominal dimensions ISO 228/1-UNI 338-66
Production tolerances on tap flank diameter
Limit dimensions for internal threads

Dimensions in mm

$P = \frac{25.4}{Z}$

$H = 0.960491 P$

$H_1 = 0.640327 P$

$r = 0.137329 P$

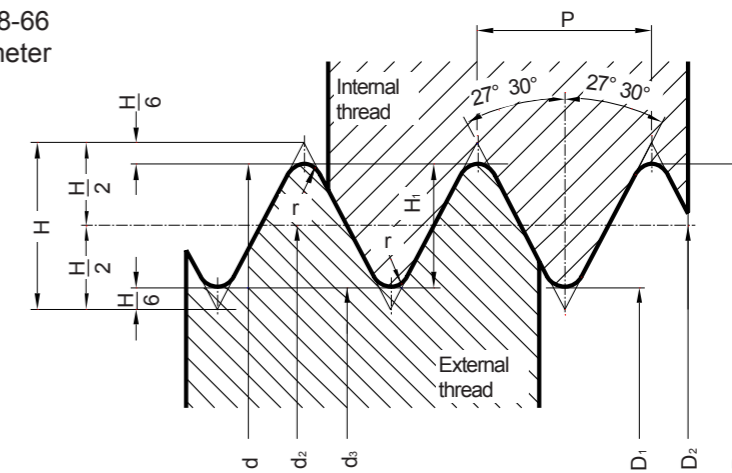

Type	Thread diameter	Pitch	TPI	Flank diameter	Minor diameter	H1	r	Tap Flank diameter		Internal Thread Flank diameter	
								min.	max.	min.	max.
G 1/8"	9.728	0.907	28	9.147	8.566	0.581	0.125	9.177	9.194	9.147	9.254
G 1/4"	13.157	1.157	19	12.301	11.445	0.856	0.184	12.336	12.356	12.301	12.426
G 3/8"	16.662	1.337	19	15.806	14.950	0.856	0.184	15.841	15.861	15.806	15.933
G 1/2"	20.955	1.814	14	19.793	18.631	1.162	0.249	19.828	19.848	19.793	19.935
G 5/8"	22.911	1.814	14	21.749	20.587	1.162	0.249	21.784	21.804	21.749	21.891
G 3/4"	26.441	1.814	14	25.279	24.117	1.162	0.249	25.314	25.334	25.279	25.421
G 7/8"	32.201	1.814	14	29.039	27.877	1.162	0.249	29.074	29.094	29.039	29.181
G 1"	33.249	2.309	11	31.770	30.291	1.479	0.317	31.815	31.839	31.770	31.950
G 1 1/8"	37.897	2.309	11	36.418	34.939	1.479	0.317	36.463	36.487	36.418	36.598
G 1 1/4"	41.910	2.309	11	40.431	38.952	1.479	0.317	40.476	40.500	40.431	40.611
G 1 3/8"	44.323	2.309	11	42.844	41.365	1.479	0.317	42.889	42.913	42.844	43.024
G 1 1/2"	47.803	2.309	11	46.324	44.845	1.479	0.317	46.374	46.398	46.324	46.504
G 1 3/4"	53.746	2.309	11	52.267	50.788	1.479	0.317	52.327	52.354	52.267	52.447
G 2"	59.614	2.309	11	58.135	56.656	1.479	0.317	58.195	58.222	58.135	58.315
G 2 1/4"	65.710	2.309	11	64.231	62.752	1.479	0.317	64.291	64.318	64.231	64.448
G 2 3/8"	69.398	2.309	11	67.919	66.440	1.479	0.317	67.979	68.006	67.919	68.136
G 2 1/2"	75.184	2.309	11	73.705	72.226	1.479	0.317	73.765	73.792	73.705	73.922
G 2 3/4"	81.534	2.309	11	80.055	78.576	1.479	0.317	80.127	80.157	80.055	80.272
G 3"	87.884	2.309	11	86.405	84.926	1.479	0.317	86.477	86.507	86.405	86.622
G 3 1/4"	93.980	2.309	11	92.501	91.022	1.479	0.317	92.573	92.603	92.501	92.718
G 3 1/2"	100.330	2.309	11	98.851	97.372	1.479	0.317	98.923	98.953	98.851	99.068
G 3 3/4"	106.680	2.309	11	105.201	103.722	1.479	0.317	105.273	105.303	105.201	105.418
G 4"	113.030	2.309	11	111.551	110.072	1.479	0.317	111.623	111.653	111.551	111.768
G 4 1/2"	125.730	2.309	11	124.251	122.772	1.479	0.317				
G 5"	138.430	2.309	11	136.951	135.472	1.479	0.317				
G 5 1/2"	151.130	2.309	11	149.651	148.172	1.479	0.317				
G 6"	163.830	2.309	11	162.351	160.872	1.479	0.317				

(1) - This type is conventional:originally the value in inches was the internal pipe diameter.

**INTERESTING HINTS FOR TAPPING**
HINWEISE ZUM GEWINDESCHNEIDEN**Selection of the most suitable tap**
Auswahl des geeigneten Gewindebohrers

Which types of tap or whether or not a thread former can be used, depends on the type of material to be machined. As a general guide, materials with an extension of at least 10% can be cold-formed.

To determine the most suitable tap, refer to the tap recommendation table on pages B4 to B23.

Welcher Typ Gewindebohrer oder ob ein Gewindeformer eingesetzt werden kann, hängt von dem zu bearbeitenden Werkstoff ab.

Als allgemeiner Leitwert gilt, daß Werkstoffe mit mindestens 10% Dehnung kaltgeformt werden können.

Zur Bestimmung des optimalen Gewindebohrers nutzen Sie die Empfehlungstabelle auf den Seiten B4 bis B23.

Core holes
Kernlöcher

- Core holes should be clean and swarf-free.
- Core holes should be of the prescribed size, see chart extract on page B317 and B378 of this catalogue, and dependent on the actual application, selected towards the upper diameter limit.
- Kernlöcher sollten sauber und spanfrei sein.
- Kernlöcher sollten die angegebenen Durchmesser haben, siehe Seiten B317 und B378, und abhängig vom aktuellen Einsatzfall, zur größtmöglichen Durchmesserangabe tendieren.

Lubricant in relation to machining centers
Schmiermitteleinsatz auf Bearbeitungszentren

Frequently the coolants used on machining centers are unsatisfactory for tapping because their percentage lubricant content is too low. If it is not possible to increase the percentage of lubricant in the emulsion, the lubrication problem can be solved in other ways, i.e.:

Meistens sind die gebräuchlichen Kühlmittel in Bearbeitungszentren zum Gewindeschneiden nicht geeignet, weil ihr Anteil an Schmierstoffen zu gering ist. Wenn es nicht möglich ist, den Anteil an Schmierstoffen in der Emulsion zu erhöhen, kann das Schmierproblem in anderer Weise gelöst werden, z. B.:

Lubricating with concentrated emulsion **Schmierung mit konzentrierter Emulsion**

- A. A lubricating unit, connected to the machine control, delivers at the required instant a specific quantity of concentrated emulsion into the core hole or onto the tap.
B. A pump in a separate tank, controlled by the machine, delivers a specific amount of concentrate into the core hole.
- A. Eine Schmiervorrichtung, die mit der Maschinensteuerung verbunden ist, gibt zum gewünschten Zeitpunkt eine bestimmte Menge konzentrierter Emulsion in das Kernloch oder auf den Gewindebohrer ab.
B. Eine Pumpe mit separatem Tank, mit der Maschinensteuerung verbunden, gibt eine bestimmte Menge des Konzentrats in das Kernloch

Tapping in separate operations **Gewindeschneiden als separater Bearbeitungsgang**

This procedure allows the use of the ideal tapping lubricant.

Dies erlaubt den Einsatz des idealen Gewindeschneid Schmiermittels.

Cutting speeds for taps
Schnittgeschwindigkeiten für Gewindebohrer

The cutting speed has a great influence on chip flow and the life of the tap.

It is worthwhile to establish the ideal cutting speed by tapping trials.

Guide values see on the recommendation table page B24. The cutting speed should be in relation to the characteristics of the material, the machine and its equipment.

Die Schnittgeschwindigkeit hat großen Einfluss auf den Spanabgang und die Lebensdauer des Gewindebohrers.

Bei Großserien ist es lohnend, die ideale Schnittgeschwindigkeit durch Versuche zu ermitteln.

Leitwerte finden Sie in der Empfehlungstabelle Seite B24. Die Schnittgeschwindigkeit sollte auf den Werkstoff, die Maschine und das Umfeld abgestimmt sein.

Effects of unsuitable cutting speed **Die Folgen falscher Schnittgeschwindigkeiten**

- forced tapping **Zu hoher Kraftaufwand**
- tap lead chipping caused by overloaded cutting tooth **Beschädigte Steigung durch überlastete Schneide**
- torn threads **Verschnittenes Gewinde**
- unsatisfactory tap-life **Ungenügende Standzeit**
- rejected threads **Ausschuss**

**Cold welding**
Kaltaufschweißung

What are the causes of cold welding? Was sind die Gründe für eine Kaltaufschweißung?

- unsuitable tap selection **Ungeeignete Gewindebohrer Auswahl**
- tap with incorrect cutting geometry **Gewindebohrer mit falscher Schneidengeometrie**
- coolant unsuitable for material **Kühlmittel ungeeignet für den Werkstoff**
- insufficient coolant **Unzureichende Kühlung**
- axial pressure (pull or push) on the tap **Axialer Druck (Zug oder Druck) auf den Gewindebohrer**
- core hole too small **Kernloch zu klein**
- breaks in walls of core hole **Risse in der Wand des Kernlochs**
- speed too high or too low **Schnittgeschwindigkeit zu hoch oder zu klein**
- swarf trapped in the hole **Verklammerter Span im Kernloch**
- incorrect alignment of tap and core hole **Achsversatz zwischen Gewindebohrer und Kernloch**
- tap eccentricity **Gewindebohrer läuft unrun**

Effects of cold welding: Die Folgen von Kaltaufschweißungen

- torn threads **verschnittene Gewinde**
- short tap life **kurze Standzeit**
- rejected threads **Ausschuss**
- tap breakage **Werkzeugbruch**
- scrap workpieces **schrottreife Werkstücke**

Tap mounting
Gewindebohrer einspannen

- The tap must be mounted on the axis of the core hole.
- On non-synchronized machines (feed / speed) we recommend the use of a tapping spindle.
- Die Achsen von Gewindebohrer und Kernloch müssen genau fluchten.
- Auf nicht synchronisierten Maschinen (Vorschub / Schnittgeschwindigkeit) empfehlen wir den Einsatz einer Gewindeschneidspindel.

Tapping heads
Gewindeschneidköpfe

With non-synchronized machine spindles (feed / speed) the feed rate should as a rule be programmed approx. 5-10% lower than the thread pitch. In these cases a tapping chuck must be used which will compensate the difference between the feed rate and the thread pitch.

It is important that the tension spring in the axial compensation is set to a light rate to avoid axially loading the tap.

The compression spring should be tensioned so that the tap starts to cut by compressing the spring at the most up to one half pitch.

Bei nicht synchronisierten Maschinenspindeln (Vorschub / Schnittgeschwindigkeit) sollte der Vorschub in der Regel 5 – 10% kleiner sein als die Gewindesteigung. In diesen Fällen muss ein Gewindeschneidfutter verwendet werden, das die Differenz zwischen dem Vorschub und der Gewindesteigung ausgleicht.

Es ist wichtig, daß die Spannfeder im axialen Ausgleich locker eingestellt wird, um eine zu große axiale Belastung des Gewindebohrers zu vermeiden.

Die Druckfeder sollte so gespannt sein, daß der Gewindebohrer zu schneiden beginnt, wenn die Feder bei höchstens einer halben Steigung gespannt ist.

Important hints: Wichtige Hinweise :

Ensure that the correct speed is selected.

Ensure that ample lubricating coolant is used when tapping.

Good machine and equipment stability is essential for optimum quality and performance.

Sorgen Sie für die richtige Schnittgeschwindigkeit.

Sorgen Sie dafür, daß reichlich Kühlschmiermittel beim Gewindeschneiden verwendet wird.

Gute Stabilität von Maschine und Vorrichtungen ist die Grundlage für optimale Qualität und Leistung.

APPLICATION AND USE OF THREADING TAPS
FEHLER UND ABHILFEN BEIM GEWINDESCHNEIDEN

Problem / FEHLER	Causes / URSACHEN	Solutions / LOSUNGEN
Tapped hole oversize Gewinde zu groß	Incorrect tap in use (cutting geometry unsuitable for application) Falscher Gewindebohrer im Einsatz (Schneidengeometrie ungeeignet)	Use tap selected from the relevant material group Einen für den Werkstoff geeigneten Gewindebohrer auswählen
	Faulty alignment Fehlerhafte Fluchtung	Ensure that the tap is correctly aligned with the core hole axis Dafür sorgen, daß Gewindebohrer und Kernloch axial genau fluchten
	Cold welding Kaltaufschweißung	Improve lubrication and direction of coolant Adjust cutting speed Schmierung und Ausrichtung des Kühlstrahls verbessern Schnittgeschwindigkeit korrigieren
	Re-ground tap (lead-in is not concentric) Nachgescharfter Gewindebohrer (Anschnitt nicht konzentrisch)	Regrind tap lead correctly on a suitable tap grinding machine Anschnitt fehlerfrei auf geeigneter Schleifmaschine nachschleifen
Stripped threads Gewinde verschnitten	Incorrect tap in use (cutting geometry incorrect for application) Falscher Gewindebohrer im Einsatz (Schneidengeometrie ungeeignet)	Use a tap from the relevant material group. Einen für den Werkstoff geeigneten Gewindebohrer auswählen
	Spindle speed and feed rate not synchronized Spindelgeschwindigkeit und Vorschub sind nicht aufeinander abgestimmt	Check feed rate programming and / or pitch of leading spindle Use a tapping spindle with axial float Vorschub und / oder Steigung der Spindel überprüfen Gewindeschneidspindel mit axialem Ausgleich verwenden
	Insufficient start pressure exerted on tap with peel-cut Unzureichender Startdruck auf einen Gewindebohrer mit Schalanschnitt	Increase start pressure Startdruck erhöhen
Bell mouthed tapped hole Gewinde trichterförmig	Incorrect start pressure applied to tap Falscher Gewindebohrer im Einsatz	Use a tapping spindle with axial float Gewindeschneidspindel mit axialem Ausgleich verwenden
Unsatisfactory thread surface finish Gewinde zu rau	Incorrect tap in use (Cutting geometry unsuitable for application) Falscher Gewindebohrer im Einsatz (Schneidengeometrie ungeeignet)	Select tap from the relevant material group Einen für den Werkstoff geeigneten Gewindebohrer auswählen
	The tap is blunt Die Schneiden sind stumpf	Replace or re-grind tap Neuen oder nachgescharften Gewindebohrer einsetzen
	Tap badly re-ground Der Gewindebohrer ist schlecht nachgescharft	Re-grind tap again. Check that cutting geometry is suitable for material Gewindebohrer korrekt nachschleifen Prüfen, ob die Schneidengeometrie für den Werkstoff geeignet ist
	Coolant lacking in lubricating qualities and / or quantity Kühlmittel mit unzureichendem Schmiermittelanteil	Ensure the use of a suitable coolant and an ample supply Für qualitativ und quantitativ gute Kühlung und Schmierung sorgen



Problem / FEHLER	Causes / URSACHEN	Solutions / LOSUNGEN
Partial chipping of tap Gewinde ist unfertig	Swarf jamming Spanestau	Check cutting speed Use alternative tap type Schnittgeschwindigkeit prüfen Andere Gewindebohrertypen wählen
	Tap has jammed against bottom of core hole Gewindebohrer ist auf den Grund des Kernlochs gefahren	Check hole and thread depths Drill core hole deeper Kernlochtiefe und Gewindelänge prüfen Kernloch tiefer bohren
	Tap incorrectly re-ground (lead-in diameter too small therefore too few cutting teeth) Gewindebohrer ist schlecht nachgescharft (Anschnittdurchmesser zu klein, deshalb zu wenige schneidende Zähne)	Ensure that original values are maintained when regrinding Beim Nachschärfen auf originale Geometrie achten
	Irregular workpiece material structure Materialfehler im Werkstück	Adjust cutting speed Improve lubricating quality of coolant Schnittgeschwindigkeit anpassen Die Schmierfähigkeit des Kühlmittels verbessern
Excessive tap wear Übermäßiger Verschleiß des Gewindebohrers	Incorrect cutting speed Falsche Schnittgeschwindigkeit	Adjust cutting speed to suit workpiece material Schnittgeschwindigkeit dem Werkstoff anpassen
	Coolant lacking in lubricating qualities and / or quantity Kühlmittel mit unzureichender Schmierqualität oder ?menge	Ensure the use of a suitable coolant and an ample supply Für qualitative und quantitative gute Kühlung und Schmierung sorgen Check that coolant is reaching the cutting zone Prüfen, ob das Kühlmittel den Schnittbereich erreicht
	Surface of the core hole is compacted Verfestigte Bohrungswand des Kernlochs	Check core hole drilling conditions (drill carefully to reduce risk of surface compacting) Einsatzwerte beim Kernlochbohren prüfen (vorsichtig bohren um eine Aufhärtung der Bohrungswand zu vermeiden) Check drill cutting edges Bohrerschneiden überprüfen
Tap breakage Bruch des Gewindebohrers	Incorrect tap in use (cutting geometry unsuitable for application) Falscher Gewindebohrer im Einsatz (Schneidengeometrie ungeeignet)	Use tap from the relevant material group Einen für den Werkstoff geeigneten Gewindebohrer auswählen
	Centering error Fehlerhafte Fluchtung	Ensure that axes of tap and core hole are aligned Dafür sorgen, daß Gewindebohrer und Kernloch axial genau fluchten
	Blunt tap Schneiden sind stumpf	Re-grind tap Neuen oder nachgescharften Gewindebohrer einsetzen Ensure that taps are stored carefully Auf sorgfältige Lagerung der Gewindebohrer achten
	Tap has reached bottom of core hole Gewindebohrer ist auf den Grund des Kernlochs gefahren	Use tapping spindle with axial float and slipping clutch Gewindeschneidspindel mit axialem Ausgleich und Rutschkupplung verwenden
	Core hole too small Kernloch ist zu klein	Select core hole as per chart, pages B317 and B378 of this catalogue Kernloch Durchmesser auf der Tabelle Seite B317 und B378 auswählen

**6** RESHARPENING
NACHSCHARFEN

The resharpening on taps is done for regenerating the active hedges worn by the destructive action of cutting and of friction, it has high importance for an economical exploitation of the tool and so far has to be made rationally, keeping away from wrong operations which can heavily compromise the accuracy and the life.

In order to execute the tap resharpening quickly and accurately we recommend the use of proper resharpening machines having all necessary equipments for this operation.

The tap resharpening take place in two steps:

- resharpening of (relieved) chamfer;
- resharpening of flutes. (See picture 1)

Das Nachscharfen der Gewindebohrer dient der Erneuerung der verschlissenen Schneidkanten.

Es ist wichtig, um das Leistungsvermögen des Werkzeugs voll auszuschnöpfen und muss daher präzise durchgeführt werden, um Fehler zu vermeiden, die die Präzision des Gewindes und die Standzeit beeinträchtigen.

Um das Nachscharfen schnell und präzise durchzuführen, empfehlen wir den Einsatz von geeigneten Schleifmaschinen mit dem notwendigen Zubehör.

Das Nachscharfen der Gewindebohrer erfolgt in zwei Stufen :

- scharfen der Freiflächen im Anschnitt;
- scharfen der Nuten (Spanfläche) (siehe Abb. 1)

RESHARPENING OF (RELIEVED) CHAMFER
RESHARPENING OF (RELIEVED) CHAMFER

The chamfer resharpening must be executed both on specific for taps machines or on conventional resharpening machines equipped with an auxiliary system proper to generate the circular relief on back.

The picture 2 shows the resharpening made with the cylindrical surface of a grinding wheel.

Before resharpening, verify that the tap, fixed between points or on pincer, runs concentrically; verify also the angle β which has to be correct in order to keep the same number of threads on chamfer.

Das Scharfen des Anschnitts muss entweder auf besonderen Gewindeschleifmaschinen erfolgen, oder auf konventionellen Schleifmaschinen mit entsprechenden Vorrichtungen für einen genauen Hinterschliff. Abb. 2 zeigt das Nachscharfen mit einer zylindrischen Schleifscheibe.

Vor dem Schleifen überprüfen, ob der Gewindebohrer, zwischen Spitzen oder in einer Spannzange gehalten, rund läuft; prüfen Sie auch den Winkel β , der korrekt sein muss, um die gleiche Anzahl Gänge im Anschnitt zu haben

RESHARPENING OF FLUTES
NACHSCHARFEN DER NUTEN

This operation must be done on a specific resharpening machine for taps, equipped with: deviding head, lead screw of "barrasinus" for executing the helix and cooling equipment.

The rake angle τ is obtained moving the tap axis, in relation to the resharpening surface, of an amount X to be calculated with the formula: $X = \frac{1}{2} d_1 \sin \tau$ (see picture 3). (d_1 =tap major diameter)

Dieser Arbeitsgang muss auf einer speziellen Gewindebohrer ? Schleifmaschine erfolgen, die ausgerüstet ist mit : Teilkopf, Leitspindel zum Schleifen entlang gedrahter Nuten und Kuhlmitelversorgung. Den Spanwinkel g bei Gewindebohrern mit geraden Nuten erhält man durch Verstellen der Bohrerachse im Verhältnis zu der zu schleifenden Oberfläche um den Einstellwert X, der nach folgender Formel errechnet wird : $X = ? d_1 \sin g$ (siehe Abb. 3). (d_1 = Gewindebohrerdurchmesser)

Example:

Tap 10 × 1,5 to cut on steel strength = 600 N/mm²

$d_1 = 10\text{mm}$; $\tau = 15^\circ$; $\sin \tau = 0,25882$;

$X = \frac{0,25882 \times 10}{2}$; $X = 1,29\text{mm}$

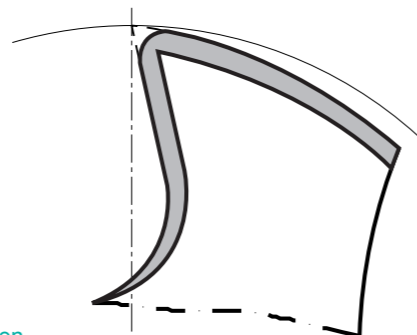

pic. 1

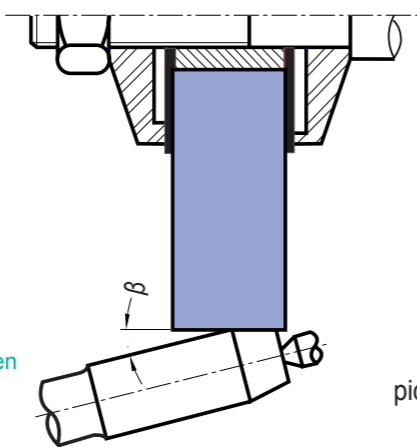

pic. 2

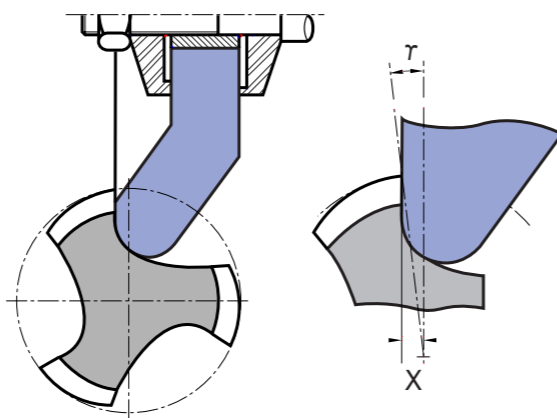

pic. 3



On all taps having spiral-flutes, in addition to the trade mark and identification of the dimension and type, it is possible to find also the pitch of the spiral referred to the lead screw necessary for the resharpening.

In case of employment of taps equipped with deburring tool Burr-Bit it is necessary to extend the flutes following what suggested by the supplier.

Because the wear on a tap is mainly on the chamfer area, on taps having "gun nose" the resharpening of the flutes can be made on the front area only (see picture 4).

Bei allen Gewindebohrern mit gedrahten

Nuten werden allgemein spezielle Schleifmaschinen eingesetzt, die die Drahlsteigung messen und selbständig einstellen können.

Beim Einsatz von Gewindebohrern mit dem Entgratwerkzeug Burr-Bit ist es notwendig, die Nuten entsprechend den Vorgaben des Herstellers zu verlängern.

Da der Verschleiß eines Gewindebohrers hauptsächlich im Anschnitt und dem erstenvollen Gewindegang liegt,

können Gewindebohrer mit Schalanschnitt und gerader Nute auch nur im vorderen

Gewindeteil nachgeschliffen werden (siehe Abb. 4).

It is very important to pay attention that, when also the thread flanks are worn (in addition to the active hedges) the resharpening as above described is practically useless.

In this case the "regeneration" is made, by means of cutting completely the chamfer away (this means a shorter tap) and reproducing then the chamfer with same angle and relief. (see picture 5)

The regeneration is also advisable on taps with spiral flutes, because that way the flutes grinding is not necessary, in absence of special resharpening machines with lead screw with proper angle.

Es ist wichtig zu wissen, daß beim Verschleiß der Gewindegangflanken (zusätzlich zur Hauptschneidkante) das oben beschriebene Nachschleifen praktisch nutzlos ist!

In diesem Fall wird die "Erneuerung" dadurch erreicht, daß der Anschnitt komplett abgetrennt wird (das bedeutet eine Kürzung des Gewindebohrers und Verlust der entrierung) und neu angeschliffen wird, mit gleichen Winkeln und Hinterschliff (siehe Abb. 5).

Diese "Erneuerung" ist auch für drahtgenutete Gewindebohrer zu empfehlen, weil dann das Nutenschleifen entfällt, wenn keine geeignete Schleifmaschine mit Leitspindel vorhanden ist

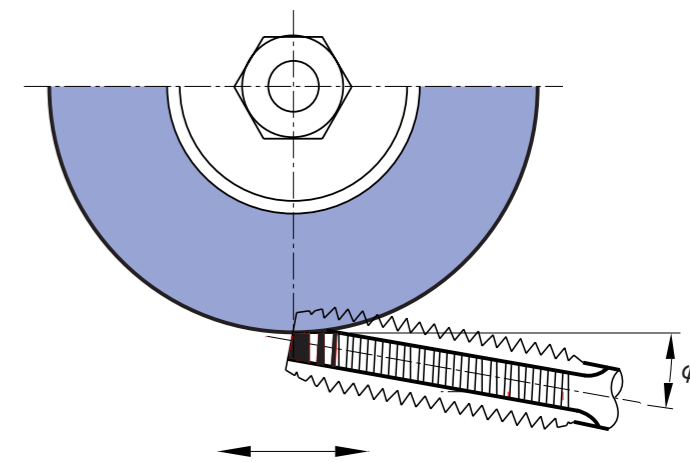

pic. 4

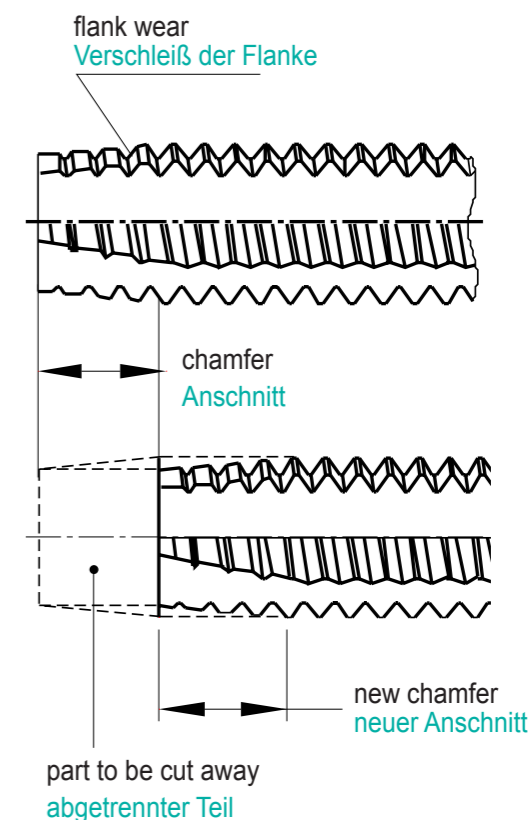

pic. 5

**IMPORTANT RECOMMENDATIONS
WICHTIGE EMPFEHLUNGEN**

**RESHARPEN TIMELY
RECHTZEITIGES NACHSCHARFEN**

It is important to resharpen timely the worn tap. In these conditions in fact defective threads can be produced, risking to brake the tool; in addition the wear is increasing quickly, damaging a wide area of the cutter and rapidly.

Es ist wichtig, den Gewindebohrer rechtzeitig nachzuschleifen. Stumpfe Gewindebohrer können defekte Gewinde schneiden, die Bruchgefahr ist erhöht; zudem nimmt der Verschleiß schnell zu und zerstört weite Bereiche der Schneiden

**PROPER GRINDING WHEELS
RICHTIGE SCHLEIFSCHLEIBEN**

The structure and grain of grinding wheels must be the right one for the tap to be resharpened. Our technicians are at complete disposal to give the proper recommendations.

Bindung und Korn der Schleifscheiben müssen auf die Gewindebohrer abgestimmt sein. Unsere Techniker sind bereit, Ihnen die geeignete Empfehlung zu geben

**TAPS FOR CAST IRONS
GEWINDEBOHRER FÜR GUSS**

On these taps the resharpening is rarely possible because, due to cast iron is abrasive, the tap is wearing on flank of the thread and so far out of tolerance.

Bei diesen Gewindebohrern ist Nachscharfen kaum möglich. Der verschleißfordernde Guss greift die Schneidenflanken an, wodurch die Toleranz verloren geht.

**TAPS FOR ALUMINIUM
GEWINDEBOHRER FÜR ALUMINIUM**

It is advisable, after resharpening as above described, to remove steel burrs from the grinding wheel action. This operation, easy with iron brushes, avoid the danger of boring or over tolerance tapping instead of accurate tapping.

Es ist empfehlenswert nach dem oben beschriebenen Nachscharfen Schleifgrate vom Gewindebohrer mit Stahlbursten zu entfernen. Dadurch wird die Gefahr vermieden, Gewinde zu groß zu schneiden.

**CONTROLS (TESTS)
KONTROLLEN (TESTS)**

Once resharpened the tap, it is always better to make some tests to obtain correct threads same as when the tap was new.

- The chamfer must be perfectly on axis to avoid the effects of picture 6.
- The cutters must have correct divisions.
- The results of a resharpening with a wrong division is shown on picture 7.
- The length and number of threads on chamfer must be rigorously identical to those of the new tap.

Nach dem Nachscharfen sollte der Gewindebohrer genau kontrolliert werden um sicher zu stellen, daß er genauso gut schneidet, wie ein neuer Bohrer.

- Der Anschnitt muss genau axial sein, um den Effekt wie in Abb. 6 zu vermeiden.
- Die Schneiden müssen eine genaue Teilung haben. Das Ergebnis des Nachschleifens mit falscher Teilung ist in Abb. 7 zu sehen.
- Die Länge und Anzahl der Gewingegänge im Anschnitt muss absolut genau so sein, wie bei einem neuen Gewindebohrer.

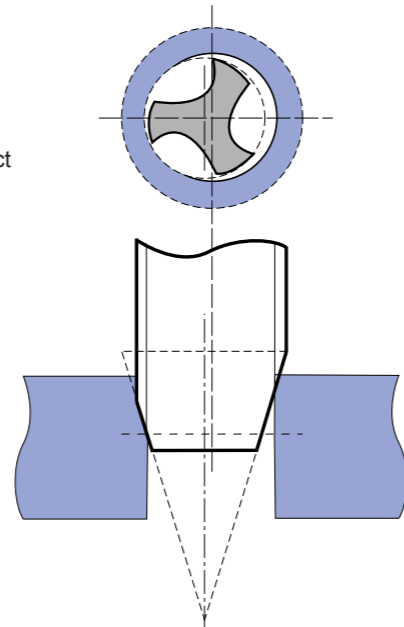

pic. 6

chamfer out of center
unrund geschliffener Anschnitt

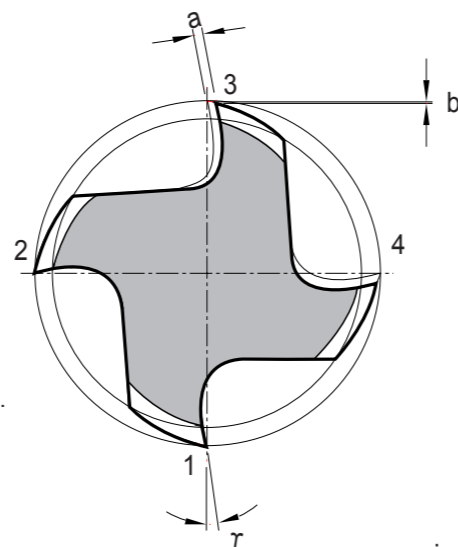

pic. 7

incorrect division
Teilungsfehler
cutters not concentric
Schneiden nicht konzentrisch

**8 ORDERS / INQUIRIES SPECIAL TAPS
Bestellungen / Anfragen ; SONDERGEWINDEBOHRER For photocopying**

Orders / Inquiries

This form may be returned to your local YG-1 distributor or to YG-1.

Company _____
Address _____
Department _____
Phone _____

Tool _____ Thread \varnothing and pitch _____

Degrees _____ R.H. _____ L.H. _____

$P =$ _____ $\text{pitch } \varnothing =$ _____ $\text{major } \varnothing =$ _____

Tolerance class _____ Overall length _____ mm

$a =$ _____ $d_1 =$ _____

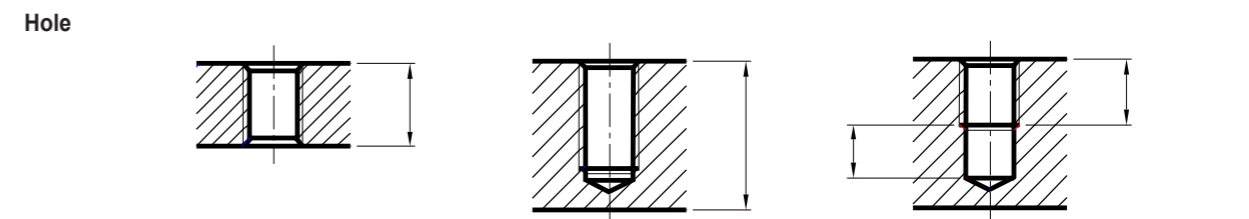

Unusual characteristics of the threaded product or of the tapping method, e.g. counterbore, tapping on an angle, etc. _____

Material to be tapped Material No. or designation _____
Tensile strength _____ N/mm² _____ HB _____ HRc
Chip form _____ short _____ long
Annealed steel _____ Hardened steel _____ Heat treated steel

Special requirements : _____

Person to be contacted within the company _____
Date _____ Signature _____

SEND US YOUR TAPPING PROBLEMS
SENDEN SIE UNS IHR GEWINDESCHNEIDPROBLEM

For photocopying

This form may be returned to your local YG-1 distributor or to YG-1.		Company _____
		Address _____
		Department _____
		Phone _____
Tool	Description of the tap being used at present Thread Ø and pitch _____ <input type="radio"/> right-hand cutting <input type="radio"/> fluteless <input type="radio"/> straight flutes <input type="radio"/> spiral point Additional information for special pitches or thread forms pitch Ø _____ major Ø _____ minor Ø _____ flank angle _____ degrees	Make _____ Type _____ Class of tolerance _____ <input type="radio"/> left-hand cutting <input type="radio"/> right hand spiral flutes _____ degrees <input type="radio"/> left hand spiral flutes _____ degrees <input type="radio"/> length of chamfer _____ thread chamfer
Hole	Tap drill Ø _____ length of hole _____ <input type="radio"/> through hole Special requirements or unusual characteristics of the threaded product _____ <input type="radio"/> bottoming hole	depth of full thread _____
Tapping speed	_____ meters per minute _____ revolutions per minute	
Lubricant	<input type="radio"/> without <input type="radio"/> emulsion _____% <input type="radio"/> cutting oil <input type="radio"/> other _____ Application <input type="radio"/> under pressure <input type="radio"/> vaporization <input type="radio"/> other _____	
Machine	Type _____ <input type="radio"/> horizontal tapping <input type="radio"/> vertical tapping	
Driving	<input type="radio"/> tap revolves <input type="radio"/> work revolves Number of spindles _____	
Feed	<input type="radio"/> without <input type="radio"/> power <input type="radio"/> CNC _____%	
Tool holder	<input type="radio"/> rigid <input type="radio"/> floating <input type="radio"/> with safety clutch Make _____ Type _____	
Material to be tapped	Material No. or designation _____ Composition, if possible _____ Tensile strength or hardness _____ N/mm ² HB _____ HRc Chip form <input type="radio"/> short <input type="radio"/> long	
Short description of problem : _____ _____ _____ _____		
Person to be contacted within the company _____ Date _____ Signature _____		

MAIN THREAD SYMBOLS
HAUFIGE GEWINDEARTE

AMERICAN STANDARD

Cylindrical threads

UNC	Unified Coarse-Thread Series
UNF	Unified Fine-Thread Series
UNEF	Unified Extra-Fine-Thread Series
UN	Constant Pitch Series-Threads with constant pitch of TPI 4,6,8,12,16,20,28,32
UNS	Selected combinations-Threads with special dia-pitch combinations
UNJ	Unified threads with constant pitch with radius on minor diameter from 0,15011 Pitch to 0,18042 Pitch
UNJC	Unified coarse thread with radius on minor diameter from 0,15011 Pitch to 0,18042 Pitch
UNJEF	Unified extra fine thread with radius on minor diameter from 0,15011 Pitch to 0,18042 Pitch
UNJF	Unified fine threads with radius on minor diameter from 0,15011 Pitch to 0,18042 Pitch

Pipe cylindrical threads

NPS	Cylindrical threads for pipe
NPSC	American Standard for pipe coupling
NPSF	American Standard for internal thread on pipe, dryseal
NPSH	American Standard for cylindrical threads for pipe, joints and nipples
NPSI	American Standard for internal cylindrical threads on pipe(dryseal)
NPSL	American Standard for cylindrical threads on pipe for nuts
NPSM	American Standard for cylindrical threads on pipe for mechanical joints
NGO	American National pipe threads for gas exhaust
NGS	American National pipe threads for gas

Taper pipe threads

ANPT	Taper pipe threads for Army, Navy and Airforce
------	--

F-PTE	Taper pipe fine threads(dryseal)
NPT	Taper pipe thread
NPTF	Taper pipe thread (dryseal)
NPTR	Taper pipe thread for railways equipments
PTF-SAE SHORT	Taper pipe short thread(dryseal)-SAE
PTF-SPL SHORT	Taper pipe special thread(dryseal)-SAE
PTF-SPL EXTRA SHORT	Extra short special thread(dryseal)-SAE
SPL-PTF	Special taper pipe dryseal thread
NGT	National American taper pipe thread
SGT	Special taper pipe thread
API	American petroleum Institute taper pipe thread

Trapezoidal and saw tooth threads

ACME-C	ACME selfcentering thread
ACME-G	ACME general application
STUB-ACME	ACME flat thread with reduced thread depth
60° STUB-ACME	ACME flat thread with 60° flank angle
N BUTT	American National Saw tooth thread

BRITISH STANDARD

BSW	Whitworth British Standard coarse pitch
BSF	Whitworth British Standard fine pitch
WHIT	Whitworth Standard special pitch
R	British Standard external threading for taper pipe(dryseal)(already BSP-Tr)
Rc	British Standard internal threading taper thread for pipe(BSP-Tr)
Rp	British Standard cylindrical thread for pipe(already BSP.PI)
BA	British Standard Association thread
BSC	British Standard thread for bicycle
CEI	British Standard for bicycle

**11** COMPARISON CHART SCALE FOR HARDNESS
VERGLEICHSTABELLE FÜR HÄRTESTALEN

Rockwell Hardness C Scale 150kg Brale (HRC)	Diamond Pyramid Hardness Number, Vickers (HV)	Brinell Hardness Standard 10mm Ball 29.42kN (HB)	Rockwell Hardness A Scale 60kg Brale (HRA)	Shore Scleroscope Hardness Number (HS)	Approx. Tensile Strength N/mm ²
68	940	-	85.6	97	-
67	900	-	85.5	95	-
66	865	-	84.5	92	-
65	832	-	83.9	91	-
64	800	-	83.4	88	-
63	772	-	82.8	87	-
62	746	-	82.3	85	-
61	720	-	81.8	83	-
60	697	-	81.2	81	-
59	674	-	80.7	80	-
58	653	-	80.1	78	-
57	633	-	79.6	76	-
56	613	-	79.0	75	-
55	595	-	78.5	74	2079
54	577	-	78.0	72	2010
53	560	-	77.4	71	1952
52	544	500	76.8	69	1883
51	528	487	76.3	68	1824
50	513	475	75.9	67	1755
49	498	464	75.2	66	1687
48	484	451	74.7	64	1639
47	471	442	74.1	63	1578
46	458	432	73.6	62	1530
45	446	421	73.1	60	1481
44	434	409	72.5	58	1432
43	423	400	72.0	57	1383
42	412	390	71.5	56	1334
41	402	381	70.9	55	1294
40	392	371	70.4	54	1245
39	382	362	69.9	52	1216
38	372	353	69.4	51	1177
37	363	344	68.9	50	1157
36	354	336	68.4	49	1118
35	345	327	67.9	48	1079
34	336	319	67.4	47	1059
33	327	311	66.8	46	1030
32	318	301	66.3	44	1000
31	310	294	65.8	43	981
30	302	286	65.3	42	952
29	294	279	64.7	41	932
28	285	271	64.3	41	912
27	279	264	63.8	40	883
26	272	258	63.3	38	863
25	266	253	62.8	38	843
24	260	247	62.4	37	824
23	254	243	62.0	36	804
22	248	237	61.5	35	785
21	243	231	61.0	35	775
20	238	226	60.5	34	755
(18)	230	219	-	33	736
(16)	222	212	-	32	706
(14)	213	203	-	31	677
(12)	204	194	-	29	647
(10)	196	187	-	28	618
(8)	188	179	-	27	598
(6)	180	171	-	26	579
(4)	173	165	-	25	549
(2)	166	158	-	24	530
(0)	160	152	-	24	520

EDP No.	Page	EDP No.	Page	EDP No.	Page
L1211	B36	TC124	B279	TCE09	B103
L1212	B37	TC127	B283	TCH14	B182
L1213	B38	TC134	B280	TCH23	B186
L1214	B39	TC144	B278	TCJ01	B126
L12D1	B48	TC163	B238	TCJ02	B128
L12D3	B49	TC169	B241	TCJ05	B114
L19E1	B50	TC170	B242	TCJ06	B115
L19E3	B51	TC174	B144	TCJ07	B116
L41A1 / L42A1	B52	TC184	B146	TCJ08	B117
L4211	B40	TC211	B295	TCJ09	B121
L4212	B41	TC214	B290	TD127	B284
L4271	B43	TC222	B286	TD174	B145
L4272	B44	TC224	B292	TD222	B288
L4273	B45	TC227	B293	TD227	B294
L4274	B46	TC234	B291	TD244	B157
L4276	B47	TC244	B156	TD263	B155
L6215	B42	TC254	B158	TD312	B139
T0993	B197	TC263	B154	TD411	B276
T0997-TIC	B210	TC283	B215	TD413	B143
T0999-TIC	B211	TC312	B138	TD422	B151
T7109	B299	TC313	B212	TD703	B252
T7309	B301	TC353	B308	TD704	B263
T7343	B306	TC411	B274	TD711	B273
T7363	B303	TC413	B142	TD713	B256
T7509	B304	TC422	B150	TD723	B260
T7609	B305	TC424	B298	TD733	B261
T7709	B313	TC433	B245	TD804	B94
TB123	B190	TC445	B124	TD814	B112
TB183	B187	TC463	B296	TD821	B199
TB264	B191	TC473	B297	TD824	B108
TB274	B192	TC517	B281	TD834	B125
TB312	B140	TC612	B282	TD844	B100
TB313	B213	TC622	B243	TD854	B118
TB373	B307	TC633	B107	TD864	B110
TB514	B316	TC711	B272	TD874	B127
TB623	B185	TC727	B317	TDE01	B109
TB711	B174	TC728	B314	TDE02	B111
TB804	B94	TC729	B315	TDE05	B96
TB814	B112	TC803	B329	TDE06	B97
TB824	B108	TC804	B94	TDE07	B98
TB834	B125	TC804-IC	B105	TDE08	B99
TB844	B100	TC807	B106	TDE09	B103
TB854	B118	TC814	B112	TDE24	B163
TB864	B110	TC814-IC	B123	TDE25	B164
TB874	B127	TC824	B108	TDE26	B165
TB904	B188	TC834	B125	TDE27	B166
TB913	B147	TC844	B100	TDE28	B167
TB914	B177	TC854	B118	TDE29	B168
TB924	B189	TC864	B110	TDJ01	B126
TBE05	B96	TC874	B127	TDJ02	B128
TBE06	B97	TC909	B321	TDJ05	B114
TBE07	B98	TC934	B324	TDJ06	B115
TBE08	B99	TC944	B323	TDJ07	B116
TBE15	B178	TC954	B325	TDJ08	B117
TBE16	B179	TC963	B240	TDJ09	B121
TBE17	B180	TC973	B322	TE403	B202
TBE18	B181	TCE01	B109	TE422	B152
TBJ05	B114	TCE02	B111	TE434	B203
TBJ06	B115	TCE05	B96	TE443	B246
TBJ07	B116	TCE06	B97	TE454	B204
TBJ08	B117	TCE07	B98	TE703	B253
TC122	B285	TCE08	B99	TE704	B264

EDP No. INDEX

EDP No.	Page
TE713	B257
TE723	B259
TE733	B262
TE821	B198
TE943	B244
TE953	B239
TI821	B200
TI914	B177
TKS35	B64
TKS36	B65
TKS43-IC	B71
TKS44-RCP	B72
TM293	B224
TM903	B222
TM923	B228
TM933	B226
TQ703	B255
TQ723	B258
TQ813	B175
TQ823	B136
TQ833	B230
TQ853	B183
TQ863	B148
TQ873	B232
TR813	B176
TR823	B137
TR833	B231
TR853	B184
TR863	B149
TR873	B233
TRE30	B77
TRE31	B79
TRE32	B81
TRE33	B82
TRE34	B78
TRJ15	B83
TRJ16	B84
TRJ17	B86
TRJ18	B87
TTS31	B60
TTS32	B61
TTS33	B62
TTS34	B63
TTS37	B66
TTS38	B67
TTS39	B68
TTS41-IC	B69
TTS42-RCP	B70
TTS45-RCP	B73
TY283	B216
TY312	B141
TY313	B214
TY422	B153
TY433	B247
TY703	B254
TY821	B201
TZ293	B225
TZ903	B223
TZ923	B229
TZ933	B227