

# Präzisionschraubstöcke

Precision vices

Étaux de précision

- 1 Einzigartiges Spannbacken-System zur Erhöhung der Spannkraft
- 2 Das patentierte Anti-Lift-System garantiert eine problemlose Bearbeitung, ohne Anhub des Werkstückes
- 3 Spannkraft mit Hilfe von Rillenmarkierungen voreinstellbar
- 4 Durch den mechanischen Spannkraftverstärker kann auch während extremer Arbeiten am Werkstück eine konstant hohe Spannkraft von bis zu 6500 kg erzielt werden
- 5 Alle Verschleißteile sind gehärtet und geschliffen

- 1 Unique clamping-jaw-system increases the clamping capacity
- 2 The new Anti-Lift mechanism ensures that the workpiece does not lift during operations
- 3 Clamping force preadjustable with the aid of graduation lines
- 4 The mechanical Booster ensures that during extreme operations a constant high clamping-force up to 6500 kg can be reached
- 5 All working parts are hardened and grinded

- 1 Unique système de mâchoire de serrage pour l'augmentation de la tension du ressort
- 2 Le nouveau mécanisme Anti-Lift assure un usinage sans problème et sans enlèvement de la pièce
- 3 La tension du ressort ce fait par préréglage avec marquage
- 4 Le répéteur de la tension du ressort assure que durant un usinage extrême la tension reste constante jusqu'à 6500 kg
- 5 Toutes les pièces d'usure sont trempées et meulées

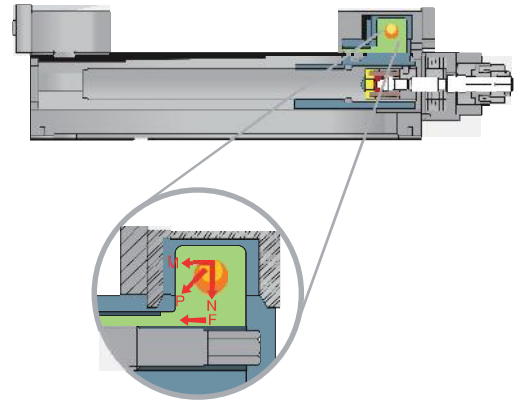

**Durch das neue Anti-Lift-System werden die Werkstücke beim Spannen niedergezogen und präzise gespannt**

*By the new Anti-lift-system workpieces get pulled-down and precisely clamped*

*Par le nouveau système Anti-Lift les pièces sont baissées et serrées précisément*

**Allseitig gehärtet und geschliffen**

*All-round hardened and grinded*  
Complètement trempés et meulés

**Stabiler Späneschutz**

*Solid chip protector*  
Protection résistant contre copeau

**Spannkraft voreinstellbar**

*Clamping force preadjustable*  
Tension du ressort ajustable d'avance

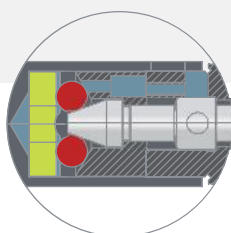
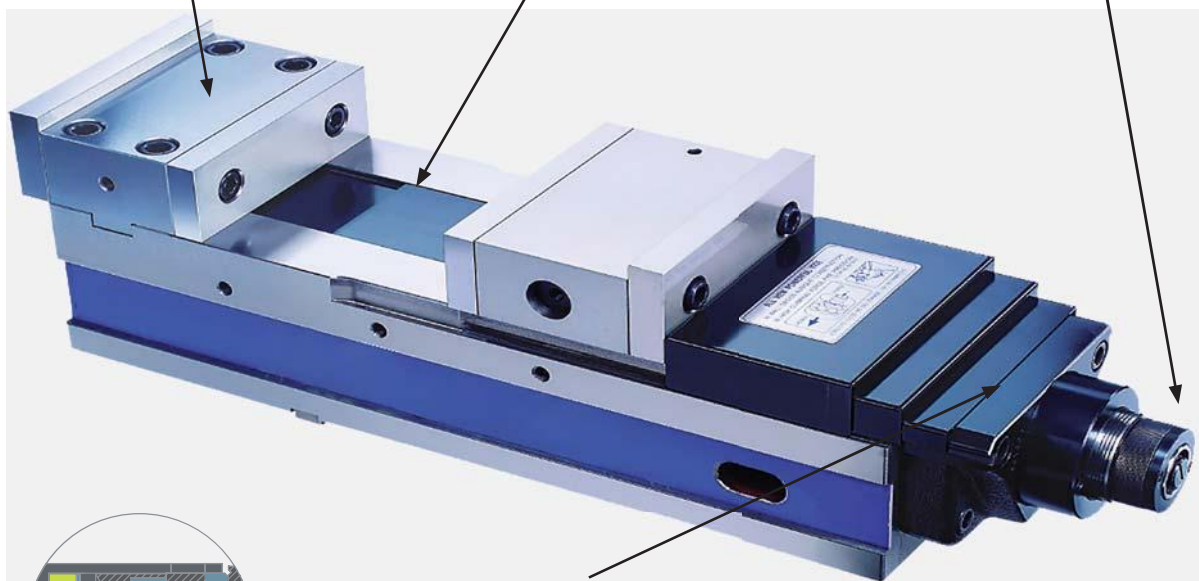

**Mechanischer Spannkraftverstärker**

*Mechanical Booster*  
Répéteur de la tension du ressort

# Inhaltsverzeichnis

Index

Table de matières

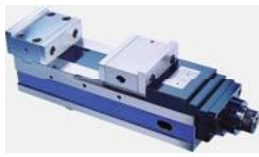

9.05



9.06

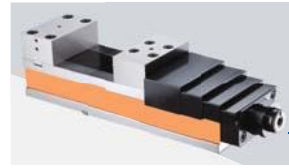

9.07



9.08



9.09



9.10



9.11



9.12



9.13



9.14



9.15



9.16



9.17



9.18



9.19



9.20



9.21



9.22

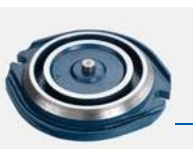

9.22



9.23



9.24



9.25

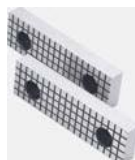

9.26



9.27

# Präzisionsschraubstöcke mechanisch mit Spannkraftverstärker

Precision vices mechanical with mechanical booster

Étaux de précision mécanique avec répéteur de la tension du ressort

## Ausführung:

- Mit mechanischem Spannkraftverstärker
- Spannkraft voreinstellbar durch Rillenmarkierung
- Horizontal, vertikal oder seitlich aufspannbar
- Stahlkörper allseitig geschliffen und gehärtet
- Eingebauter Niederzug
- Betthöhe H:  $\leq 0,01$  mm

## Lieferumfang:

- Bedienungsanleitung
- Incl. Spannschlüssel
- 4 Stück Spannpratzen
- 4 Stück T-Nutensteine 18mm
- Messprotokoll

## Spannkraft:

KS01010 = 57 kN  
KS01020 = 67 kN

## Construction:

- With mechanical booster
- Clamping force preadjustable by graduation lines
- Clamping positions: horizontal, vertical and lateral
- The steel body is hardened and grinded all-round
- Integrated pull-down mechanism
- Bed height H:  $\leq 0,01$  mm

## Delivery:

- Instructions for use
- Wrench
- 4 pcs. vice clamps
- 4 pcs. T-nuts 18mm
- Test certificate

## Type:

- Avec répéteur de la tension du ressort
- La tension du ressort ce fait par pré réglage avec marquage.
- Positions de serrage: horizontale, verticale ou latérale
- Corps en acier trempé et rectifié sur toutes les faces
- Répression basse incorporée
- Hauteur du socle H:  $\leq 0,01$  mm

## Livraison avec:

- Mode d'emploi
- Clé de serrage
- 4 Mors de serrage
- 4 Tasseaux pour rainures en T
- Protocole de mesure

## Clamping force:

KS01010 = 57 kN  
KS01020 = 67 kN

## Tension du ressort:

KS01010 = 57 kN  
KS01020 = 67 kN

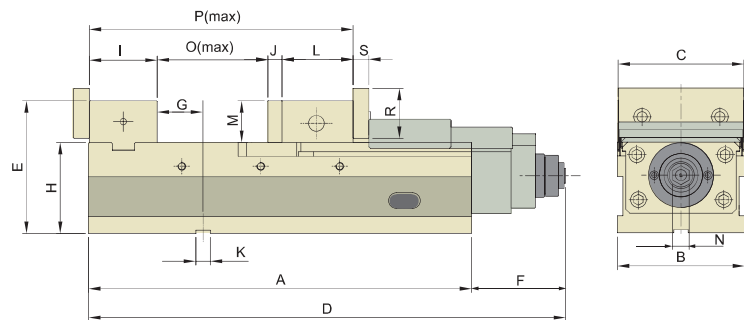
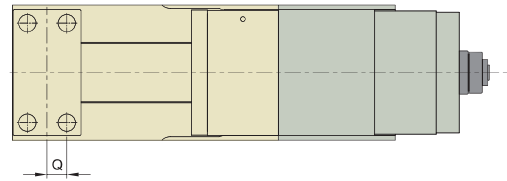
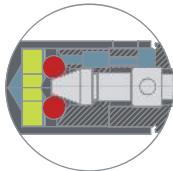
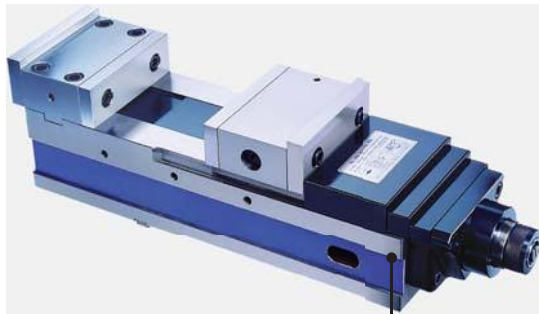

## Mit patentiertem mechanischem Spannkraftverstärker:

- 1 kein Ölverlust
- 2 genaue Wiederholbarkeit der Spannkraft
- 3 keine Veränderung der Spannkraft
- 4 keine Vibrationen während der Bearbeitung
- 5 lange Lebensdauer

## With patented mechanical booster:

- 1 no loss of oil
- 2 exact repeatability of the clamping force
- 3 constant clamping force
- 4 no vibrations during the operation
- 5 long life

## Avec répéteur de la tension du ressort patenté:

- 1 pas de déchet d'huile hydraulique
- 2 répétabilité exacte de la tension du ressort
- 3 tension du ressort constante
- 4 pas de vibrations durant l'usinage
- 5 durabilité longue

Bestell-Nr. Order no. Référence	Ausführung Version Type	A	B	C	D	E	F	G	H	I	J	K	L	M	N	O	P	Q	R	S	kN	kg
KS01010	ALQ-160G/HV	515	161	159,5	635	168	120	76	115	86	18	18	80	53	19	330,0	514,0	25	63	20	57	76
KS01020	ALQ-200G/HV	585	202	200,0	713	178	128	93	120	101	18	18	95	58	19	367,5	581,5	31	73	20	67	108

# Präzisionsschraubstöcke mechanisch mit Spannkraftverstärker

Precision vices mechanical with mechanical booster

Étaux de précision mécanique avec répéteur de la tension du ressort

### Ausführung:

- Mit mechanischem Spannkraftverstärker
- Spannkraft voreinstellbar durch Rillenmarkierung
- Horizontal, vertikal oder seitlich aufspannbar
- Stahlkörper allseitig geschliffen und gehärtet
- Eingebauter Niederzug
- Betthöhe H: ≤ 0,01 mm

### Lieferumfang:

- Bedienungsanleitung
- Incl. Spannschlüssel
- 4 Stück Spannpratzen
- 4 Stück T-Nutensteine 18mm
- Messprotokoll

### Spannkraft:

KS02010 = 25 kN  
 KS02020 = 35 kN  
 KS02030 = 45 kN  
 KS02040 = 50 kN

### Construction:

- With mechanical booster
- Clamping force preadjustable by graduation lines
- Clamping positions: horizontal, vertical and lateral
- The steel body is hardened and grinded all-round
- Integrated pull-down mechanism
- Bed height H: ≤ 0,01 mm

### Delivery:

- Instructions for use
- Wrench
- 4 pcs. vice clamps
- 4 pcs. T-nuts 18 mm
- Test certificate

### Clamping force:

KS02010 = 25 kN  
 KS02020 = 35 kN  
 KS02030 = 45 kN  
 KS02040 = 50 kN

### Type:

- Avec répéteur de la tension du ressort
- La tension du ressort ce fait par pré réglage avec marquage.
- Positions de serrage: horizontale, verticale ou latérale
- Corps en acier trempé et rectifié sur toutes les faces
- Répression basse incorporée
- Hauteur du socle H: ≤ 0,01 mm

### Livraison avec:

- Mode d'emploi
- Clé de serrage
- 4 Mors de serrage
- 4 Tasseaux pour rainures en T
- Protocole de mesure

### Tension du ressort:

KS02010 = 25 kN  
 KS02020 = 35 kN  
 KS02030 = 45 kN  
 KS02040 = 50 kN

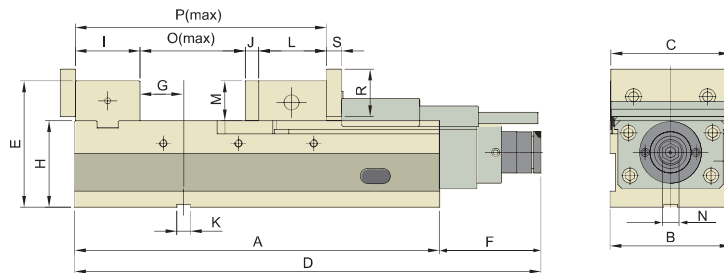
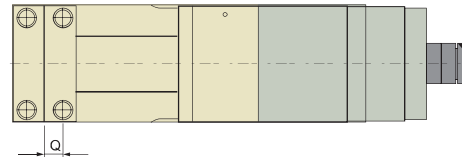
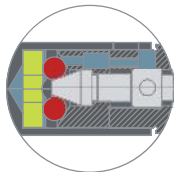

### Mit patentiertem mechanischem Spannkraftverstärker:

- 1 kein Ölverlust
- 2 genaue Wiederholbarkeit der Spannkraft
- 3 keine Veränderung der Spannkraft
- 4 keine Vibrationen während der Bearbeitung
- 5 lange Lebensdauer

### With patented mechanical booster:

- 1 no loss of oil
- 2 exact repeatability of the clamping force
- 3 constant clamping force
- 4 no vibrations during the operation
- 5 long life

### Avec répéteur de la tension du ressort patenté:

- 1 pas de déchet d'huile hydraulique
- 2 répétabilité exacte de la tension du ressort
- 3 tension du ressort constante
- 4 pas de vibrations durant l'usinage
- 5 durabilité longue

Bestell-Nr. Order no. Référence	Ausführung Version Type	A	B	C	D	E	F	G	H	I	J	K	L	M	N	O	P	Q	R	S	kN	kg
KS02010	AVQ-100G/HV	324	104	102	428	130	104	41	85	73	15	18	86,5	45	14	140	314,5	20	55	17	25	30
KS02020	AVQ-125G/HV	390	127	125	495	153	105	66	100	78	15	18	87,5	53	14	201	381,5	22,5	63	20	35	46
KS02030	AVQ-160G/HV	485	161	159,5	605	168	120	58	115	86	18	18	80	53	14	295	479	25	63	20	45	71
KS02040	AVQ-200G/HV	535	202	200	655	178	128	75	120	101	18	18	95	58	14	320	534	31	73	20	50	100

## Präzisionsschraubstöcke mechanisch mit Spannkraftverstärker

Precision vices mechanical with mechanical booster

Étaux de précision mécanique avec répéteur de la tension du ressort

### Ausführung:

- Mit mechanischem Spannkraftverstärker
- Spannkraft voreinstellbar durch Rillenmarkierung
- Horizontal und vertikal aufspannbar
- Stahlkörper allseitig geschliffen und gehärtet
- Eingebauter Niederzug
- Betthöhe H:  $\leq 0,01$  mm

### Lieferumfang:

- Bedienungsanleitung
- Incl. Spannschlüssel
- 4 Stück Spannpratzen
- 4 Stück T-Nutensteine 18mm
- Messprotokoll

### Spannkraft:

KS14010 = 45 kN

### Construction:

- With mechanical booster
- Clamping force preadjustable by graduation lines
- Clamping positions: horizontal and vertical
- The steel body is hardened and grinded all-round
- Integrated pull-down mechanism
- Bed height H:  $\leq 0,01$  mm

### Delivery:

- Instructions for use
- Wrench
- 4 pcs. vice clamps
- 4 pcs. T-nuts 18mm
- Test certificate

### Clamping force:

KS14010 = 45 kN

### Type:

- Avec répéteur de la tension du ressort
- La tension du ressort ce fait par préréglage avec marquage.
- Positions de serrage: horizontale ou verticale
- Corps en acier trempé et rectifié sur toutes les faces
- Répression basse incorporée
- Hauteur du socle H:  $\leq 0,01$  mm

### Livraison avec:

- Mode d'emploi
- Clé de serrage
- 4 Mors de serrage
- 4 Tasseaux pour rainures en T
- Protocole de mesure

### Tension du ressort:

KS14010 = 45 kN

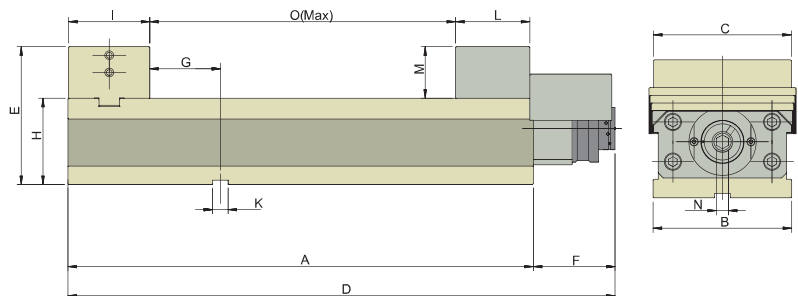
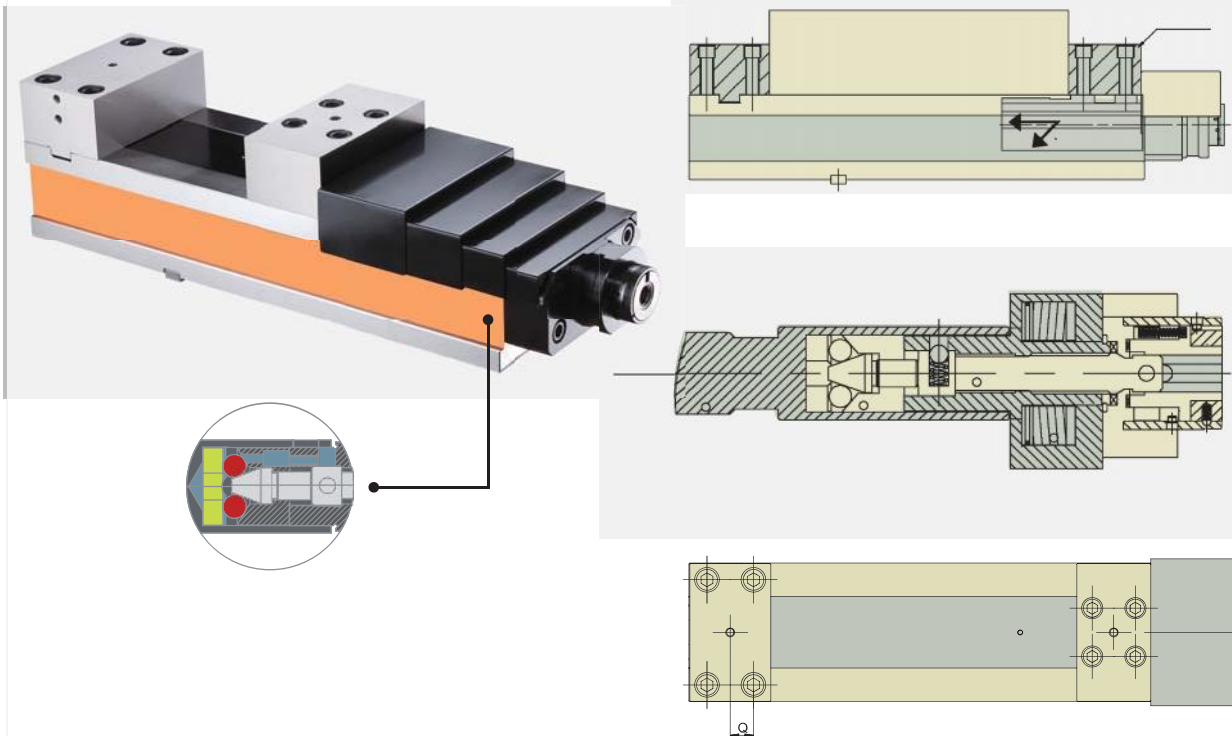

Bestell-Nr. Order no. Référence	Ausführung Version Type	A	B	C	D	E	F	G	H	I	K	M	N	O	Q	kN	kg
KS14010	AVK-160G/HV	540	161	160	635	160	95	82	100	94	18	60	14	355	27	45	65

## Präzisionsschraubstöcke Zentrischspanner mechanisch

Precision vices self-centering mechanical

Étaux de précision etau autocentrant mécanique

### Ausführung:

- Horizontal, vertikal oder seitlich aufspannbar
- Stahlkörper allseitig geschliffen und gehärtet
- Eingebauter Niederzug
- Betthöhe H:  $\leq 0,01$  mm

### Construction:

- Clamping positions: horizontal, vertical and lateral
- The steel body is hardened and grinded all-round
- Integrated pull-down mechanism
- Bed height H:  $\leq 0,01$  mm

### Type:

- Positions de serrage: horizontale, verticale ou latérale
- Corps en acier trempé et rectifié sur toutes les faces
- Répression basse incorporée
- Hauteur du socle H:  $\leq 0,01$  mm

### Lieferumfang:

- Bedienungsanleitung
- Incl. Spannschlüssel
- 4 Stück Spannpratzen
- 4 Stück T-Nutensteine 18mm
- Messprotokoll

### Delivery:

- Instructions for use
- Wrench
- 4 pcs. vice clamps
- 4 pcs. T-nuts 18mm
- Test certificate

### Livraison avec:

- Mode d'emploi
- Clé de serrage
- 4 Mors de serrage
- 4 Tasseaux pour rainures en T
- Protocole de mesure

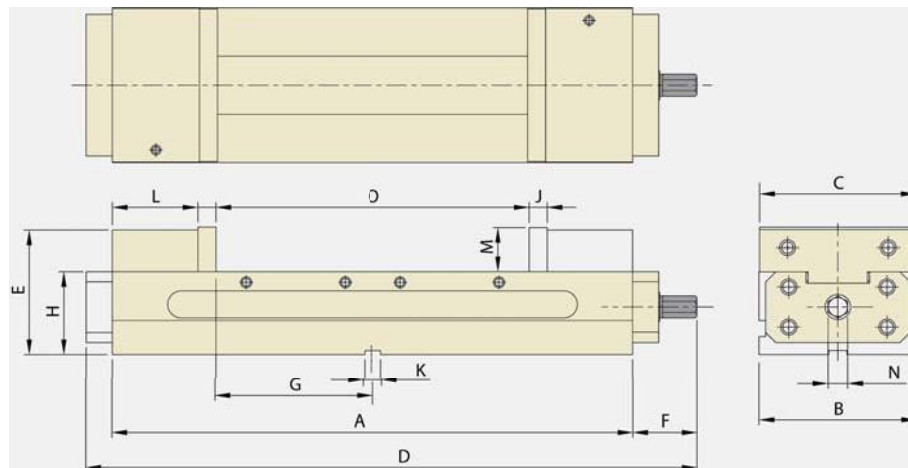

Bestell-Nr. Order no. Référence	Ausführung Version Type	A	B	C	D	E	F	G	H	J	K	L	M	N	O	T	U	kg
KS19010	HLD-60GG/HV	520	154	152	610	124,05	64	260	82,55	18	18	85	44,5	19	58-314	23,8	98,4	52

## Präzisionsschraubstöcke mechanisch mit Spannkraftverstärker

Precision vices mechanical with mechanical booster

Étaux de précision mécanique avec répéteur de la tension du ressort

### Ausführung:

- Mit mechanischem Spannkraftverstärker
- Spannkraft voreinstellbar durch Rillenmarkierung
- Horizontal, vertikal oder seitlich aufspannbar
- Stahlkörper allseitig geschliffen und gehärtet
- Eingebauter Niederzug
- Betthöhe H:  $\leq 0,01$  mm

### Lieferumfang:

- Bedienungsanleitung
- Incl. Spannschlüssel
- 4 Stück Spannpratzen
- 4 Stück T-Nutensteine 18mm
- Messprotokoll

### Spannkraft:

KS15010 = 45 kN  
KS15020 = 60 kN

### Construction:

- With mechanical booster
- Clamping force preadjustable by graduation lines
- Clamping positions: horizontal, vertical and lateral
- The steel body is hardened and grinded all-round
- Integrated pull-down mechanism
- Bed height H:  $\leq 0,01$  mm

### Delivery:

- Instructions for use
- Wrench
- 4 pcs. vice clamps
- 4 pcs. T-nuts 18mm
- Test certificate

### Clamping force:

KS15010 = 45 kN  
KS15020 = 60 kN

### Type:

- Avec répéteur de la tension du ressort
- La tension du ressort ce fait par préréglage avec marquage.
- Positions de serrage: horizontale, verticale ou latérale
- Corps en acier trempé et rectifié sur toutes les faces
- Répression basse incorporée
- Hauteur du socle H:  $\leq 0,01$  mm

### Livraison avec:

- Mode d'emploi
- Clé de serrage
- 4 Mors de serrage
- 4 Tasseaux pour rainures en T
- Protocole de mesure

### Tension du ressort:

KS15010 = 45 kN  
KS15020 = 60 kN

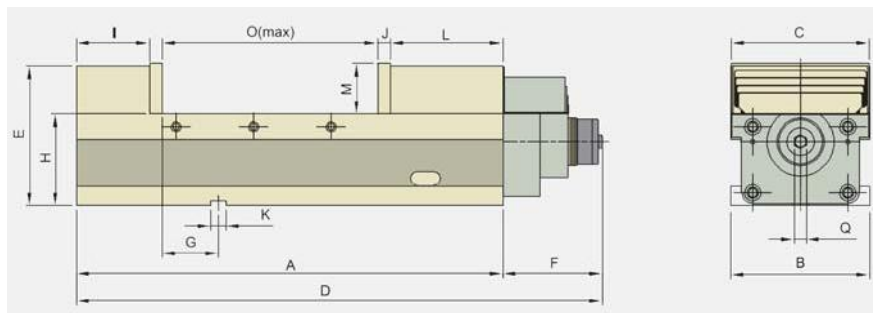
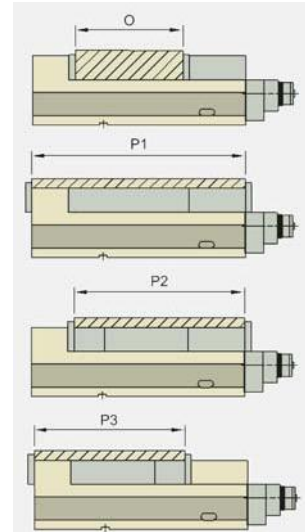
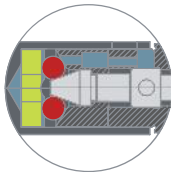

Bestell-Nr. Order no. Référence	Ausführung Version Type	A	B	C	D	E	F	G	H	I	J	K	L	M	N	O	P1	P2	P3	kN	kg
KS15010	AVM-160G/HV	495	161	160	610	160	115	65	105	85	15	18	130	58	19	250	250-480	250-370	250-330	45	55
KS15020	AVM-200G/HV	580	201	200	708	170	128	85	110	90	18	18	150	63	19	290	290-550	290-430	290-370	60	78



## Präzisionsschraubstöcke mechanisch

Precision vices mechanical

Étaux de précision mécanique

### Ausführung:

- Horizontal, vertikal oder seitlich aufspannbar
- Stahlkörper allseitig geschliffen und gehärtet
- Eingebauter Niederzug
- Betthöhe H:  $\leq 0,01$  mm

### Construction:

- Clamping positions: horizontal, vertical and lateral
- The steel body is hardened and grinded all-round
- Integrated pull-down mechanism
- Bed height H:  $\leq 0,01$  mm

### Type:

- Positions de serrage: horizontale, verticale ou latérale
- Corps en acier trempé et rectifié sur toutes les faces
- Répression basse incorporée
- Hauteur du socle H:  $\leq 0,01$  mm

### Lieferumfang:

- Bedienungsanleitung
- Incl. Spanschlüssel
- 4 Stück Spannpratzen
- 4 Stück T-Nutensteine 18mm
- Messprotokoll

### Delivery:

- Instructions for use
- Wrench
- 4 pcs. vice clamps
- 4 pcs. T-nuts 18mm
- Test certificate

### Livraison avec:

- Mode d'emploi
- Clé de serrage
- 4 Mors de serrage
- 4 Tasseaux pour rainures en T
- Protocole de mesure

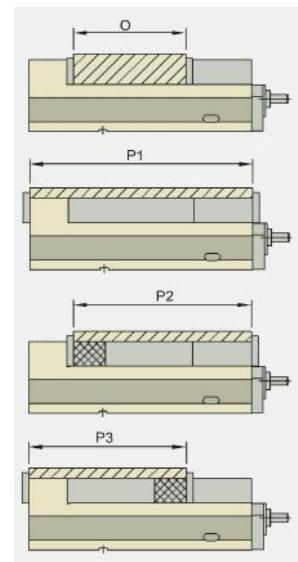
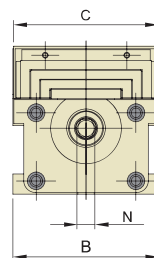
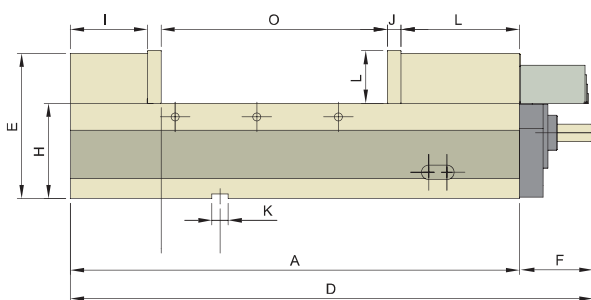

Bestell-Nr. Order no. Référence	Ausführung Version Type	A	B	C	D	E	F	G	H	I	J	K	L	M	N	O	P1	P2	P3	kg
KS16010	AVC-160G/HV	495	161	160	576	160	81	65	105	85	15	18	130	58	19	250	250-480	250-370	250-330	52
KS16020	AVC-200G/HV	580	201	200	670	170	90	85	110	90	18	18	130	63	19	250	290-550	290-430	290-370	75





## Präzisionsschraubstöcke mechanisch

Precision vices mechanical

Étaux de précision mécanique

### Ausführung:

- Horizontal, vertikal oder seitlich aufspannbar
- Stahlkörper allseitig geschliffen und gehärtet
- Eingebauter Niederzug
- Betthöhe H:  $\leq 0,01$  mm

### Construction:

- Clamping positions: horizontal, vertical and lateral
- The steel body is hardened and grinded all-round
- Integrated pull-down mechanism
- Bed height H:  $\leq 0,01$  mm

### Type:

- Positions de serrage: horizontale, verticale ou latérale
- Corps en acier trempé et rectifié sur toutes les faces
- Répression basse incorporée
- Hauteur du socle H:  $\leq 0,01$  mm

### Lieferumfang:

- Bedienungsanleitung
- Incl. Spannschlüssel
- 4 Stück Spannpratzen
- 4 Stück T-Nutensteine 18mm
- Messprotokoll

### Delivery:

- Instructions for use
- Wrench
- 4 pcs. vice clamps
- 4 pcs. T-nuts 18mm
- Test certificate

### Livraison avec:

- Mode d'emploi
- Clé de serrage
- 4 Mors de serrage
- 4 Tasseaux pour rainures en T
- Protocole de mesure

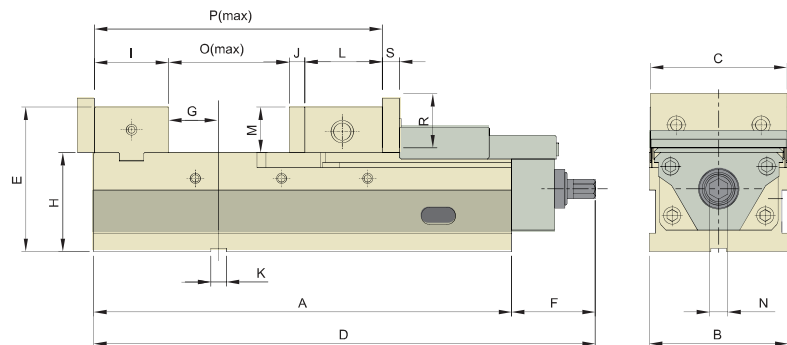
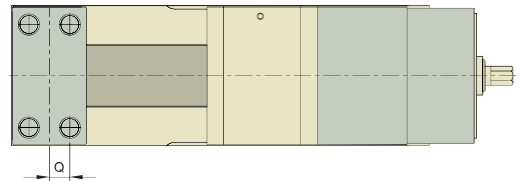

Bestell-Nr. Order no. Référence	Ausführung Version Type	A	B	C	D	E	F	G	H	I	J	K	L	M	N	O	P	Q	R	S	kg
KS05010	AVL-100G/HV	324	104	102,0	437	130	104	41	85	73	15	18	86,5	45	19	140	314,5	20,0	55	17	27
KS05020	AVL-125G/HV	390	127	125,0	480	153	105	66	100	78	15	18	87,5	53	19	201	381,5	22,5	63	20	43
KS05030	AVL-160G/HV	485	161	159,5	625	225	120	76	115	86	18	18	80,0	53	21	295	479,0	25,0	63	20	71
KS05040	AVL-200G/HV	535	202	199,5	660	260	128	93	120	101	18	18	95,0	58	19	320	534,0	31,0	73	20	98



# Präzisionsschraubstöcke Pneumatik hydraulisch

Precision vices pneumatic hydraulic

Étaux de précision pneumatiques hydrauliques

## Ausführung:

- Geeignet für Serienfertigung
- Horizontal und vertikal aufspannbar
- Stahlkörper allseitig geschliffen und gehärtet
- Eingebauter Niederzug
- Betthöhe H:  $\leq 0,01$  mm

## Lieferumfang:

- Bedienungsanleitung
- Incl. Spannschlüssel
- 4 Stück Spannpratzen
- 4 Stück T-Nutensteine 18mm
- Messprotokoll

## Construction:

- Suitable for mass production
- Clamping positions: horizontal and vertical
- The steel body is hardened and grinded all-round
- Integrated pull-down mechanism
- Bed height H:  $\leq 0,01$  mm

## Delivery:

- Instructions for use
- Wrench
- 4 pcs. vice clamps
- 4 pcs. T-nuts 18mm
- Test certificate

## Type:

- Approprié à la fabrication en série
- Positions de serrage: horizontale, ou verticale
- Corps en acier trempé et rectifié sur toutes les faces
- Répression basse incorporée
- Hauteur du socle H:  $\leq 0,01$  mm

## Livraison avec:

- Mode d'emploi
- Clé de serrage
- 4 Mors de serrage
- 4 Tasseaux pour rainures en T
- Protocole de mesure

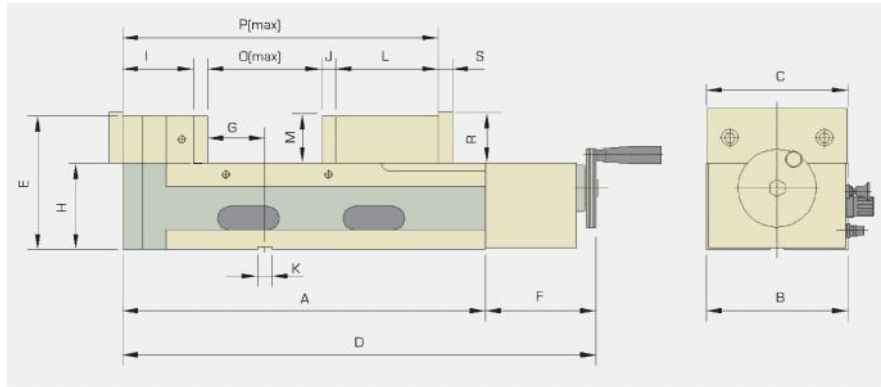
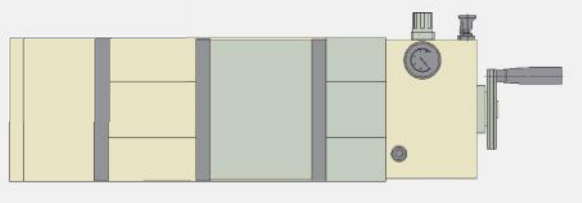

Bestell-Nr. Order no. Référence	Ausführung Version Type	A	B	C	D	E	F	G	H	I	J	K	L	M	N	O	P	R	S	kN	kg
KS18150	AMP-150G/HV	380	130	130	520	157	140	60	105	85	15	18	110	52	-	0-150	200-380	62	15	62	52
KS18160	AMP-160G/HV	400	160	160	540	157	140	60	105	87	15	18	120	52	-	0-160	210-400	62	15	62	58
KS18165	AMP-165G/HV	490	160	160	630	157	140	60	105	87	15	18	120	55	-	0-250	210-490	65	15	62	65
KS18180	AMP-180G/HV	460	180	180	600	170	140	90	110	90	18	18	130	60	-	0-200	220-460	70	18	90	75
KS18200	AMP-200G/HV	470	200	200	610	170	140	90	110	90	18	18	140	60	-	0-200	230-470	70	18	90	82
KS18300	AMP-300G/HV	570	200	200	710	170	140	90	110	90	18	18	140	60	-	0-300	230-570	70	18	90	93



# Doppelspannstöcke mechanisch

Twin vices mechanical

Étaux à double serrage mécanique

### Ausführung:

- Doppelspannung mit 2 beweglichen und einer festen Spannbacke
- Horizontal und vertikal aufspannbar
- Stahlkörper allseitig geschliffen und gehärtet
- Eingebauter Niederzug
- Spannwiederholgenauigkeit  $\leq 0,01$  mm
- Mittenspanngenauigkeit  $\leq 0,01$  mm
- Betthöhe H:  $\leq 0,01$  mm

### Construction:

- Double-clamping via two mobile and one fixed jaw.
- Clamping positions: horizontal, and vertical
- The steel body is hardened and grinded all-round
- Integrated pull-down mechanism
- Repeating accuracy  $\leq 0,01$  mm
- Clamping accuracy at the centre  $\leq 0,01$  mm
- Bed height H:  $\leq 0,01$  mm

### Type:

- Double serrage avec deux mâchoires mobile et une mâchoire fixe
- Positions de serrage: horizontale, ou verticale
- Corps en acier trempé et rectifié sur toutes les faces
- Répression basse incorporée
- Précision de la répétition  $\leq 0,01$  mm
- Précision de la répétition au centre  $\leq 0,01$  mm
- Hauteur du socle H:  $\leq 0,01$  mm

### Lieferumfang:

- Bedienungsanleitung
- Incl. Spannschlüssel
- 4 Stück Spannpratzen
- 4 Stück T-Nutensteine 18mm
- Messprotokoll

### Delivery:

- Instructions for use
- Wrench
- 4 pcs. vice clamps
- 4 pcs. T-nuts 18mm
- Test certificate

### Livraison avec:

- Mode d'emploi
- Clé de serrage
- 4 Mors de serrage
- 4 Tasseaux pour rainures en T
- Protocole de mesure

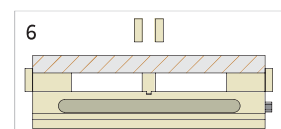
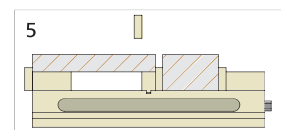
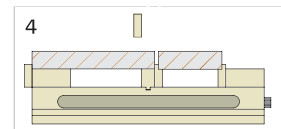
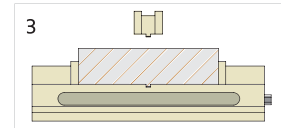
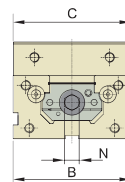
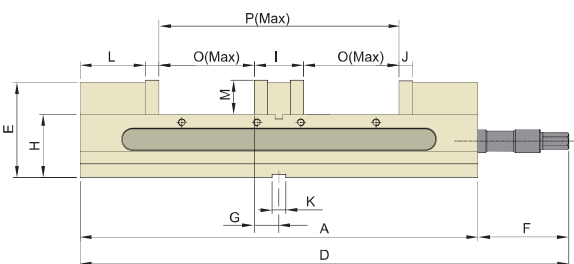
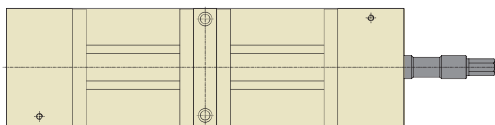
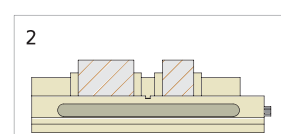
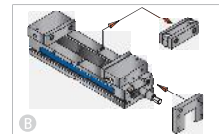
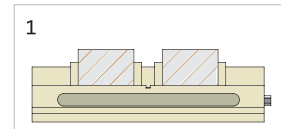
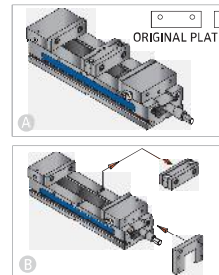

Bestell-Nr. Order no. Référence	Ausführung Version Type	A	B	C	D	E	F	G	H	I	J	K	L	M	N	O	P	kg
KS09010	TLD-40G/HV	405	104	103	459	96,5	54	27,5	63,50	55	15	18	69	38,0	14	90	235	20
KS09020	TLD-60G/HV	520	154	153	536	124,05	16	33,0	82,55	66	18	18	86,5	44,5	19	125	316	52

# Doppelspannstöcke mechanisch

Twin vices mechanical

Étaux à double serrage mécanique

### Ausführung:

- Doppelspannung mit 2 beweglichen und einer festen Spannbacke
- Horizontal und vertikal aufspannbar
- Stahlkörper allseitig geschliffen und gehärtet
- Eingebauter Niederzug
- Spannwiederholgenauigkeit  $\leq 0,01$  mm
- Mittenspanngenauigkeit  $\leq 0,01$  mm
- Betthöhe H:  $\leq 0,01$  mm

### Construction:

- Double-clamping via two mobile and one fixed jaw.
- Clamping positions: horizontal and vertical
- The steel body is hardened and grinded all-round
- Integrated pull-down mechanism
- Repeating accuracy  $\leq 0,01$  mm
- Clamping accuracy at the centre  $\leq 0,01$  mm
- Bed height H:  $\leq 0,01$  mm

### Type:

- Double serrage avec deux mâchoires mobile et une mâchoire fixe
- Positions de serrage: horizontale ou verticale
- Corps en acier trempé et rectifié sur toutes les faces
- Répression basse incorporée
- Précision de la répétition  $\leq 0,01$  mm
- Précision de la répétition au centre  $\leq 0,01$  mm
- Hauteur du socle H:  $\leq 0,01$  mm

### Lieferumfang:

- Bedienungsanleitung
- Incl. Spannschlüssel
- 4 Stück Spannpratzen
- 4 Stück T-Nutensteine 18mm
- Messprotokoll

### Delivery:

- Instructions for use
- Wrench
- 4 pcs. vice clamps
- 4 pcs. T-nuts 18mm
- Test certificate

### Livraison avec:

- Mode d'emploi
- Clé de serrage
- 4 Mors de serrage
- 4 Tasseaux pour rainures en T
- Protocole de mesure

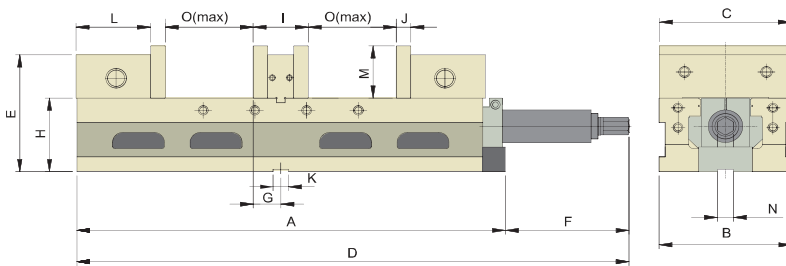
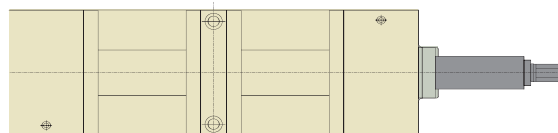
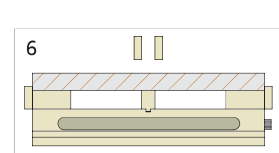
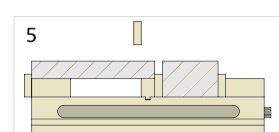
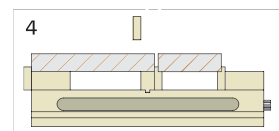
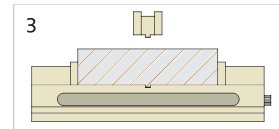
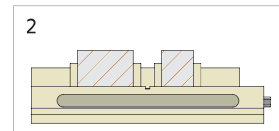
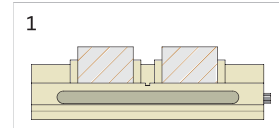
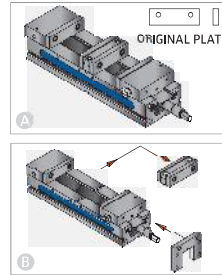

Bestell-Nr. Order no. Référence	Ausführung Version Type	A	B	C	D	E	F	G	H	I	J	K	L	M	N	O	kg
KS10010	ALD-60G/HV	497	154	152	610	143	113	32	90	64	17	18	86,5	58	14	34-102	63,5



## Präzisionsschraubstöcke mechanisch

Precision vices mechanical

Étaux de précision mécanique

### Ausführung:

- Horizontal, vertikal oder seitlich aufspannbar
- Stahlkörper allseitig geschliffen und gehärtet
- Eingebauter Niederzug
- Betthöhe H:  $\leq 0,01$  mm

### Construction:

- Clamping positions: horizontal, vertical and lateral
- The steel body is hardened and grinded all-round
- Integrated pull-down mechanism
- Bed height H:  $\leq 0,01$  mm

### Type:

- Positions de serrage: horizontale, verticale ou latérale
- Corps en acier trempé et rectifié sur toutes les faces
- Répression basse incorporée
- Hauteur du socle H:  $\leq 0,01$  mm

### Lieferumfang:

- Bedienungsanleitung
- Incl. Spanschlüssel
- Messprotokoll

### Delivery:

- Instructions for use
- Wrench
- Test certificate

### Livraison avec:

- Mode d'emploi
- Clé de serrage
- Protocole de mesure

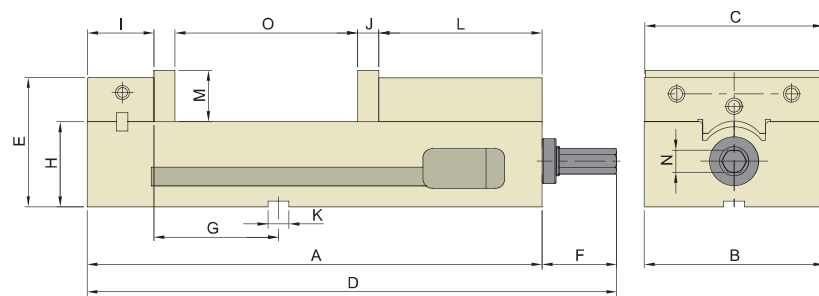

Bestell-Nr. Order no. Référence	Ausführung Version Type	A	B	C	D	E	F	G	H	I	J	K	L	M	N	O	kg
KS12010	AMC-40G/HV	330	105	102	372	100	42	82,6	68	46,8	21	18	106	40,0	14	125	21,0
KS12020	AMC-60G/HV	390	154	153	455	111	65	123	73	57,0	18	18	140	44,5	19	148	36,5



## Präzisionsschraubstöcke mechanisch

Precision vices mechanical

Étaux de précision mécanique

### Ausführung:

- Horizontal und vertikal aufspannbar
- Stahlkörper geschliffen und gehärtet
- Eingebauter Niederzug
- Betthöhe H:  $\leq 0,01$  mm

### Construction:

- Clamping positions: horizontal and vertical
- The steel body is hardened and grinded
- Integrated pull-down mechanism
- Bed height H:  $\leq 0,01$  mm

### Type:

- Positions de serrage: horizontale ou verticale
- Corps en acier trempé et rectifié sur toutes
- Répression basse incorporée
- Hauteur du socle H:  $\leq 0,01$  mm

### Lieferumfang:

- Bedienungsanleitung
- Incl. Spannschlüssel
- Messprotokoll

### Delivery:

- Instructions for use
- Wrench
- Test certificate

### Livraison avec:

- Mode d'emploi
- Clé de serrage
- Protocole de mesure

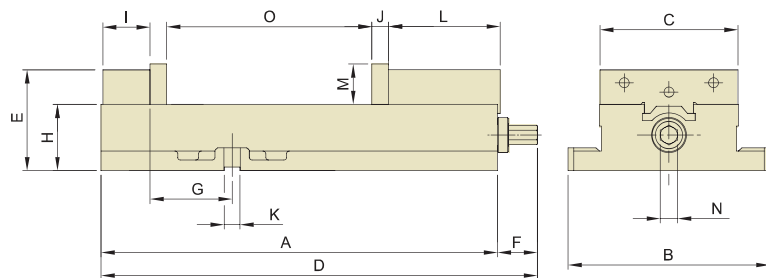

Bestell-Nr. Order no. Référence	Ausführung Version Type	A	B	C	D	E	F	G	H	I	J	K	L	M	N	O	kg
KS11010	ATW-40	312,5	166	103,5	352,5	85,65	40	71	57,15	35,1	15	12	102	35,0	14,0	103,9	18
KS11020	ATW-50	368,0	194	127,0	404,0	97,00	36	85	63,5	40,5	17	16	120	38,1	16,0	127,0	25
KS11030	ATW-675	432,0	235	152,0	476,0	111,02	44	108	73,02	52,0	18	17,48 / 18	123	44,5	19,0	192,0	36
KS11040	ATW-689	437	222	152	481,0	111,025	44	90,5	73,025	52	18	17,48 / 18	123	44,5	19,0	226,0	36
KS11050	ATW-810	555	295	203	585,0	134,074	30	125,7	84,074	58	24,2	20,65 / 18	157	56,0	19,0	265,0	68



## Präzisionsschraubstöcke mechanisch

Precision vices mechanical

Étaux de précision mécanique

### Ausführung:

- Horizontal, vertikal oder seitlich aufspannbar
- Stahlkörper allseitig geschliffen und gehärtet
- Eingebauter Niederzug
- Betthöhe H:  $\leq 0,01$  mm

### Construction:

- Clamping positions: horizontal, vertical and lateral
- The steel body is hardened and grinded all-round
- Integrated pull-down mechanism
- Bed height H:  $\leq 0,01$  mm

### Type:

- Positions de serrage: horizontale, verticale ou latérale
- Corps en acier trempé et rectifié sur toutes les faces
- Répression basse incorporée
- Hauteur du socle H:  $\leq 0,01$  mm

### Lieferumfang:

- Bedienungsanleitung
- Incl. Spannschlüssel
- Messprotokoll

### Delivery:

- Instructions for use
- Wrench
- Test certificate

### Livraison avec:

- Mode d'emploi
- Clé de serrage
- Protocole de mesure

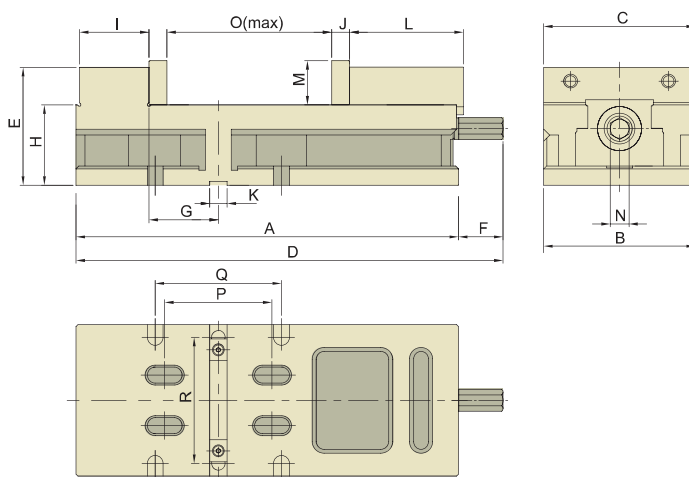

Bestell-Nr. Order no. Référence	Ausführung Version Type	A	B	C	D	E	F	G	H	I	J	K	L	M	N	O	P	Q	R	kg
KS13010	MG-60G/HV	385	152,45	152	431,8	118,7	46,8	61,1	81	69,9	18	18	114,3	44,5	19	163	107,95	127	127	31



## Präzisionsschraubstöcke hydraulisch

Precision vices hydraulic

Étaux de précision hydraulique

### Ausführung:

- Spannkraft voreinstellbar durch Rillenmarkierung
- Horizontal und vertikal aufspannbar
- 50° schwenkbar
- Führungen geschliffen und gehärtet

### Lieferumfang:

- Bedienungsanleitung
- Incl. Spannschlüssel
- Messprotokoll

### Spannkraft:

KS08010 = 25 kN  
KS08020 = 44 kN

### Construction:

- Clamping force preadjustable by graduation lines
- Clamping positions: horizontal and vertical
- 50° pivotable
- Slides hardened and grinded

### Delivery:

- Instructions for use
- Wrench
- Test certificate

### Clamping force:

KS08010 = 25 kN  
KS08020 = 44 kN

### Type:

- La tension du ressort ce fait par préréglage avec marquage.
- Positions de serrage: horizontale ou verticale
- Pivotant de 50°
- Rainures trempées et rectifiées

### Livraison avec:

- Mode d'emploi
- Clé de serrage
- Protocole de mesure

### Tension du ressort:

KS08010 = 25 kN  
KS08020 = 44 kN

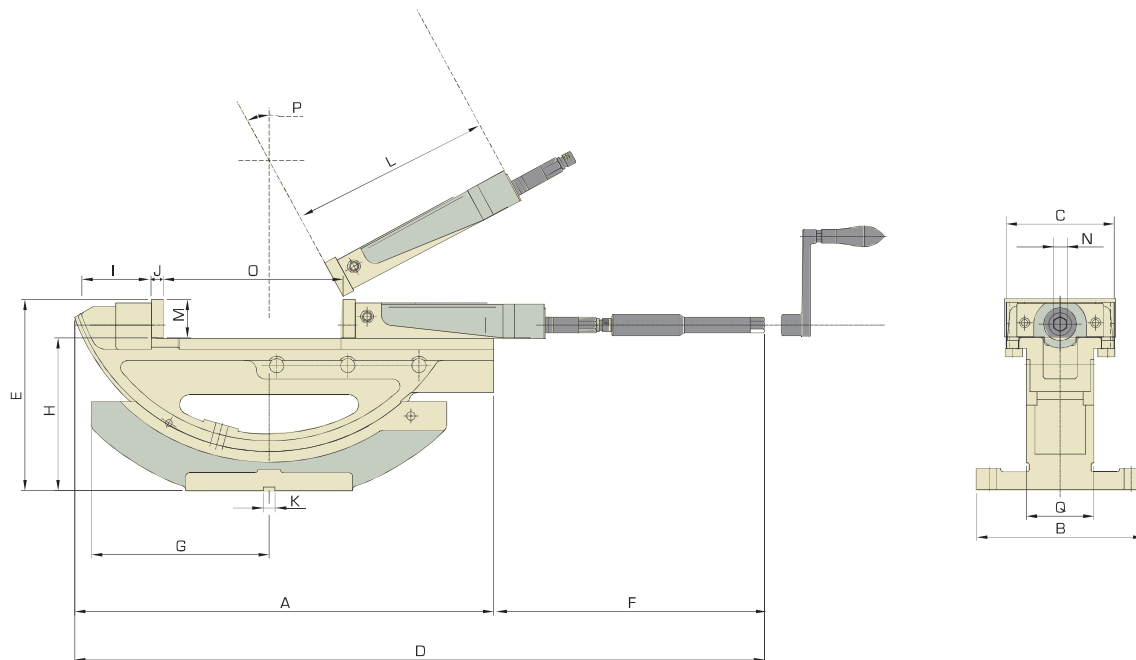

Bestell-Nr. Order no. Référence	Ausführung Version Type	A	B	C	D	Winkel E Angle E Angle E	F	G	H	I	J	K	L	M	N	O	P	Q	kN	kg
KS08010	HPT-40	330	160	104	525	177	195	172	141	65	11	16	153	36	14	170	50	65,0	25	28
KS08020	HPT-60	590	235	152	812	264	222	250	210	97	15	16	175	54	19	300	50	94,5	44	75



## Präzisionsschraubstöcke mechanisch mit Spannkraftverstärker

Precision vices mechanical with mechanical booster

Étaux de précision mécanique avec répéteur de la tension du ressort

### Ausführung:

- Mit mechanischem Spannkraftverstärker
- Spannkraft voreinstellbar durch Rillenmarkierung
- Horizontal und vertikal aufspannbar
- Führungen geschliffen und gehärtet
- Betthöhe H:  $\leq 0,01$  mm

### Lieferumfang:

- Bedienungsanleitung
- Incl. Spannschlüssel
- Messprotokoll

### Spannkraft:

KS06010 = 40 kN  
KS06020 = 50 kN  
KS06030 = 60 kN

### Construction:

- With mechanical booster
- Clamping force preadjustable by graduation lines
- Clamping positions: horizontal and vertical
- Slides hardened and grinded
- Bed height H:  $\leq 0,01$  mm

### Delivery:

- Instructions for use
- Wrench
- Test certificate

### Clamping force:

KS06010 = 40 kN  
KS06020 = 50 kN  
KS06030 = 60 kN

### Type:

- Avec répéteur de la tension du ressort
- La tension du ressort ce fait par pré réglage avec marquage.
- Positions de serrage: horizontale ou verticale
- Rainures trempées et rectifiées
- Hauteur du socle H:  $\leq 0,01$  mm

### Livraison avec:

- Mode d'emploi
- Clé de serrage
- Protocole de mesure

### Tension du ressort:

KS06010 = 40 kN  
KS06020 = 50 kN  
KS06030 = 60 kN

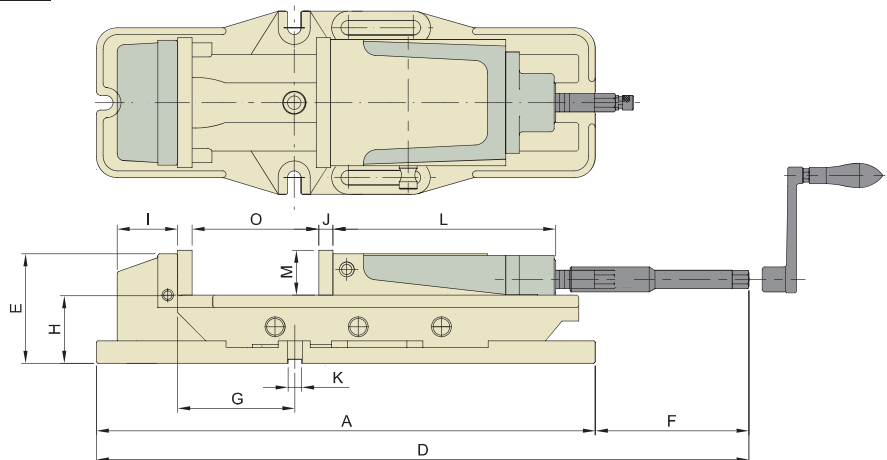
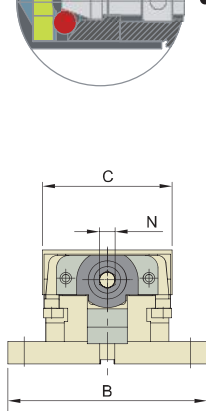
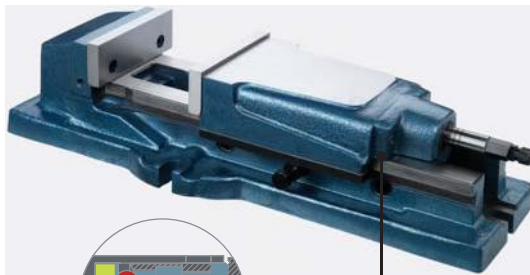

### Mit patentiertem mechanischem Spannkraftverstärker:

- 1 kein Ölverlust
- 2 genaue Wiederholbarkeit der Spannkraft
- 3 keine Veränderung der Spannkraft
- 4 keine Vibrationen während der Bearbeitung
- 5 lange Lebensdauer

### With patented mechanical booster:

- 1 no loss of oil
- 2 exact repeatability of the clamping force
- 3 constant clamping force
- 4 no vibrations during the operation
- 5 long life

### Avec répéteur de la tension du ressort patenté:

- 1 pas de déchet d'huile hydraulique
- 2 répétabilité exacte de la tension du ressort
- 3 tension du ressort constante
- 4 pas de vibrations durant l'usinage
- 5 durabilité longue

Bestell-Nr. Order no. Référence	Ausführung Version Type	A	B	C	D	E	F	G	H	I	J	K	L	M	N	O	kN	kg
KS06010	MP-50A	538	185	130	670	117	132	82	72	76	15	16	175	46	19	220	40	38
KS06020	MP-60A	620	240	154	800	132	180	140	82	82	17	16	208	54	19	300	50	58
KS06030	MP-80A	700	280	206	900	160	200	118	100	100	21	18	245	62	19	300	60	104

## Präzisionsschraubstöcke hydraulisch

Precision vices hydraulic

Étaux de précision hydraulique

### Ausführung:

- Spannkraft voreinstellbar durch Rillenmarkierung
- Horizontal und vertikal aufspannbar
- Führungen geschliffen und gehärtet
- Eingebauter Niederzug
- Betthöhe H:  $\leq 0,01$  mm

### Lieferumfang:

- Bedienungsanleitung
- Incl. Spannschlüssel
- Messprotokoll

### Spannkraft:

KS07010 = 25 kN  
 KS07020 = 35 kN  
 KS07030 = 44 kN  
 KS07040 = 66 kN

### Construction:

- Clamping force preadjustable by graduation lines
- Clamping positions: horizontal and vertical
- Slides hardened and grinded
- Integrated pull-down mechanism
- Bed height H:  $\leq 0,01$  mm

### Delivery:

- Instructions for use
- Wrench
- Test certificate

### Clamping force:

KS07010 = 25 kN  
 KS07020 = 35 kN  
 KS07030 = 44 kN  
 KS07040 = 66 kN

### Type:

- La tension du ressort ce fait par pré réglage avec marquage.
- Positions de serrage: horizontale, ou verticale
- Rainures trempées et rectifiées
- Répression basse incorporée
- Hauteur du socle H:  $\leq 0,01$  mm

### Livraison avec:

- Mode d'emploi
- Clé de serrage
- Protocole de mesure

### Tension du ressort:

KS07010 = 25 kN  
 KS07020 = 35 kN  
 KS07030 = 44 kN  
 KS07040 = 66 kN

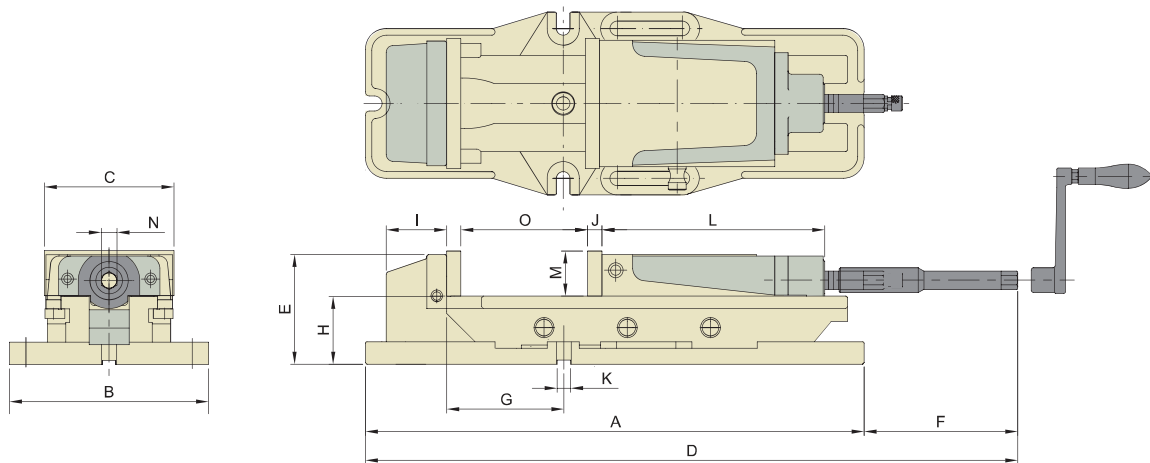

Bestell-Nr. Order no. Référence	Ausführung Version Type	A	B	C	D	E	F	G	H	I	J	K	L	M	N	O	kN	kg
KS07010	HP-40A	435	160	104	525	93	90	53	58	76	11	16	153	36	14	170	25	24
KS07020	HP-50A	538	185	130	670	117	132	82	72	82	15	16	175	46	19	220	35	37
KS07030	HP-60A	620	240	154	800	132	180	140	82	81	17	16	208	54	19	300	44	58
KS07040	HP-80A	700	280	206	900	160	200	118	100	101	21	18	245	62	19	300	66	104

## Schleif- und Kontrollschraubstöcke mit Gewindespindel

Grinding and inspection vices with threaded spindle

Etaux de contrôle et de rectification à réglage à vis

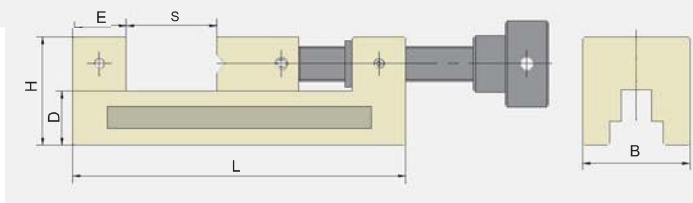
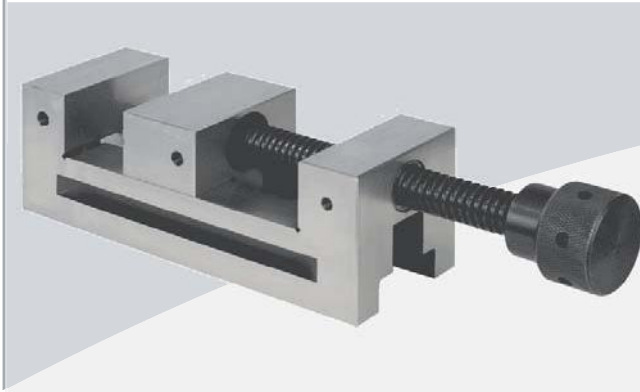

Bestell-Nr. Order no. Référence	B	H	E	D	S <sub>max</sub>	L	kg
90.11.050	50	50	25	25	65	155	3
90.11.073	73	74	32	39	100	210	5
90.11.100	100	95	38	50	125	260	13

## Schleif- und Kontrollschraubstöcke mit Schnellverstellung

Grinding and inspection vices with quick adjustment

Etaux de contrôle et de rectification à réglage rapide

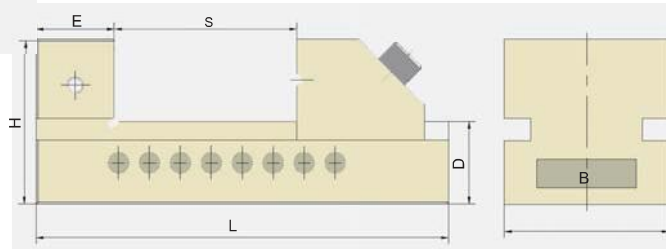

Bestell-Nr. Order no. Référence	B	H	E	D	S <sub>max</sub>	L	kg
90.12.050	50	50	30	25	65	140	2
90.12.073	73	67	35	32	100	190	5
90.12.100	100	90	47	45	125	245	11

## Universal-Schleif- und Kontrollschraubstöcke

Universal, grinding and inspection vices

Etaux de contrôle et de rectification universel

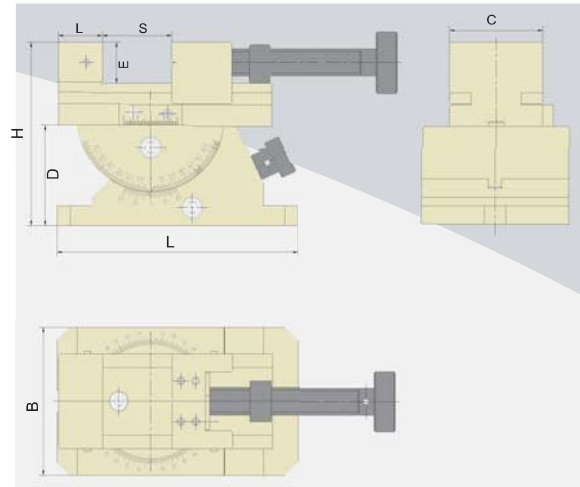
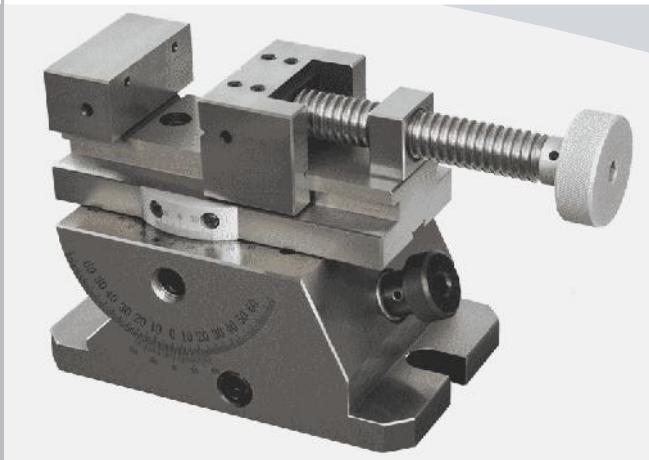

Bestell-Nr.  
Order no.  
Référence

Bestell-Nr. Order no. Référence	B	H	D	E	C	S <sub>max</sub>	L	kg
90.17.080	110	137	75	30	70	80	180	12

## Drehplatte

Swivel base

Plateau tournant

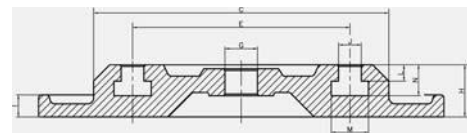
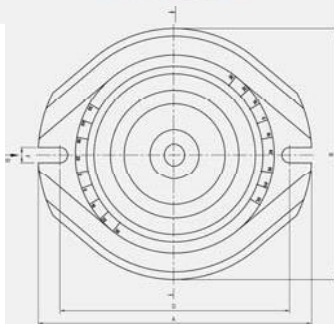

Bestell-Nr.  
Order no.  
Référence

Ausführung  
Version  
Type

Bestell-Nr. Order no. Référence	Ausführung Version Type	A	B	C	D	E	F	G	H	I	J	K	L	M	N
Z.KS.HP402A	HP-40	233	220	167	197	125	12	16	25	25	11	0	7	19	15
Z.KS.HP502A	HP-50 / MP-50	272	260	212	239	160	18	16	33	33	14	0	10	26	22
Z.KS.HP602A	HP-60 / MP-60	327	322	255	286	201	20	16	37	37	18	0	12	32	23
Z.KS.HP802A	HP-80 / MP-80	410	410	305	370	240	20	16	46	46	18	0	15	36	27
Z.KS.AT413A	ATW-40	250	230	182	210	134	14	20	32	13,5	14	0	10	23,5	19
Z.KS.AT513A	ATW-50	275	257	212	239	163	14	20	36	13,5	14	0	10	23,5	19
Z.KS.AT613A	ATW-675 / ATW689	320	300	255	280	191	20	25	42	14,5	17,5	0	13	34	30
Z.KS.AT813A	ATW-810	400	380	320	356	250	20	30	49	20	17	0	15	32	33

## Parallel-Unterlagen-Sätze

Set of parallel supports

Jeu de supports parallèles



### Verwendung:

Parallelunterlagen finden vielseitige Verwendung als Hilfsmittel zum Spannen und Positionieren z.B. beim Schleifen, Fräsen, Erodieren, Messen und Anreissen.

### Application:

Parallels are widely used for clamping and positioning, f.e. during grinding, milling, eroding, measuring and scribing.

### Application:

Parallèles sont largement utilisés pour le serrage et le positionnement, p.e. pendant le meulage, fraisage, électroérosion, mesurage et traçage.

Bestell-Nr. Order no. / Référence	Ausführung Version / Type
91.12.150.1	14 x 2 - 150 x 10 x 14 (16,18,20,22,24,26,28,30,32,35,40,45,50)
91.12.150.2	14 x 2 - 150 x 8 x 14 (16,18,20,22,24,26,28,30,32,35,40,45,50)
91.12.200.3	14 x 2 - 200 x 10 x 14 (16,18,20,22,24,26,28,30,32,35,40,45,50)
91.13.100.1	9 x 2 - 100 x 4 x 10 (14,18,22,26,30,34,38,42)

**Härte:** HRC 55 - 62  
**Hardeness:** HRC 55 - 62  
**Dureté:** HRC 55 - 62

**Genauigkeit:** 0,01mm  
**Accuracy:** 0,01mm  
**Exactitude:** 0,01mm

**Parallelität:** 0,005mm  
**Parallelism:** 0,005mm  
**Parallélisme:** 0,005mm

## Ersatzbacken-Paare

Pair of spare jaws

Paire de mors de rechange



Bestell-Nr. Order no. Référence	Ausführung Version Type	Abmessung Size Dimension
Z.KS.SA.AT409	ATW-40	102 x 35 x 15
Z.KS.SA.AT509	ATW-50 / AMC-50	126 x 38,1 x 17
Z.KS.SA.ATL609	ATW-675 / ATW-689 / MG-60 / AMC-60 / TLD-60	151 x 44,5 x 18
Z.KS.SA.ATL809	ATW-810	206 x 56 x 24,2
Z.KS.SA.AMC409	AMC-40	102 x 40 x 21
Z.KS.SA.AVQ4401	AVQ-100 / AVL-100	102 x 45 x 15
Z.KS.SA.AVQ5401	AVQ-125 / AVL-125	124,7 x 53 x 15
Z.KS.SA.AVQ6401	AVQ-160 / AVL-160 / ALQ-160	159,2 x 53 x 18
Z.KS.SA.AVQ8401	AVQ-160 / AVL-200 / ALQ-160	199,5 x 58 x 18
Z.KS.SA.HP403	HP-40	104 x 36 x 11
Z.KS.SA.HP503	HP-50 / MP-50	130 x 46 x 15
Z.KS.SA.HP603	HP-60 / MP-60	154 x 54 x 17
Z.KS.SA.HP803	HP-80 / MP-80	206 x 62 x 21
Z.KS.SA.AVC6401	AVC-160 / AVM-160	160 x 58 x 15
Z.KS.SA.AVC8401	AVC-200 / AVM-200	200 x 63 x 18
Z.KS.SA.TLD4401	TLD-40	102 x 38 x 15
Z.KS.ST.ALD6403	ALD-60	152 x 58 x 17

## Prismenbacken

Prismatic jaws

Mors prismatiques

Bestell-Nr. Order no. Référence	Ausführung Version Type	Abmessung Size Dimension	Größe Vee Type
Z.KS.PR.AT409R	ATW-40	102 x 35 x 31	40 x 120°
Z.KS.PR.AT509R	ATW-50	126 x 38,1 x 31	40 x 120°
Z.KS.PR.AT609R	ATW-675 / 689 / MG-60 / AMC-60 / TLD-60	151 x 44,5 x 31	45 x 120°
Z.KS.PR.AT809R	ATW-810	206 x 60 x 36	60 x 120°
Z.KS.PR.AVQ4407	AVQ / AVL-100	102 x 45 x 28	36,26 x 120°
Z.KS.PR.AVQ5407	AVQ / AVL-125	124,7 x 53 x 31	50 x 120°
Z.KS.PR.AVQ6407	AVQ / AVL-160	159,2 x 53 x 31	55 x 120°
Z.KS.PR.AVQ8407	AVQ / AVL-200	200 x 56 x 31	55 x 120°
Z.KS.PR.HP403R	HP-40	104 x 36 x 31	40 x 120°
Z.KS.PR.HP503R	HP / MP-50	130 x 46 x 31	45 x 120°
Z.KS.PR.HP603R	HP / MP-60	154 x 54 x 31	55 x 120°
Z.KS.PR.HP803R	HP / MP-80	206 x 62 x 36	60 x 120°
Z.KS.PR.AVC6407	AVC / AVM-160	160 x 58 x 30	55 x 120°
Z.KS.PR.AVC8407	AVC / AVM-200	200 x 63 x 36	70 x 120°
Z.KS.PR.TLD4404	TLD-40	102 x 38 x 31	40 x 120°
Z.KS.PR.ALD6404	ALD-60	152 x 58 x 49	55 x 120°



## Stufenbacken (Paar)

Step jaws (Pair)

Mors étagés (Paire)

Bestell-Nr. Order no. Référence	Ausführung Version Type	Abmessung Size Dimension	Stufe Step Cran
Z.KS.ST.AT409L	ATW-40	102 x 35 x 15	4 x 3,5
Z.KS.ST.AT509L	ATW-50	126 x 38,1 x 17	4 x 3,5
Z.KS.ST.AT609L	ATW-675 / 689 / MG-60 / AMC-60 / TLD-60	151 x 44,5 x 18	5 x 4,5
Z.KS.ST.AT809L	ATW-810	206 x 56 x 24,2	6 x 5,5
Z.KS.ST.AVQ4404	AVQ / AVL-100	102 x 45 x 15	5 x 5
Z.KS.ST.AVQ5404	AVQ / AVL-125	124,7 x 53 x 15	5 x 5
Z.KS.ST.AVQ6404	AVQ / AVL-160	159,2 x 53 x 18	5 x 4,5
Z.KS.ST.AVQ8404	AVQ / AVL-200	200 x 56 x 18	4 x 5
Z.KS.ST.AVC6404	AVC / AVM-160	160 x 58 x 15	5 x 5
Z.KS.ST.AVC8404	AVC / AVM-200	200 x 63 x 18	5 x 5
Z.KS.ST.AMC409L	AMC-40	102 x 40 x 21	4 x 3,5
Z.KS.ST.TLD4402	TLD-40	102 x 38 x 15	8 x 5
Z.KS.ST.ALD6403	ALD-60	152 x 58 x 17	8 x 5



## Geriffelte Backen / Rillenbacken (Paar)

Serrated jaws (Pair)

Mors à rainures (Paire)

Bestell-Nr. Order no. Référence	Ausführung Version Type	Abmessung Size Dimension	Raster Grid Type
Z.KS.GR.AT409T	ATW-40	102 x 35 x 15	9 x 9
Z.KS.GR.AT509T	ATW-50	126 x 38,1 x 17	9 x 9
Z.KS.GR.AT609T	ATW-675 / 689 / MG-60 /AMC-60 / TLD-60	151 x 44,5 x 18	8 x 8
Z.KS.GR.AT809T	ATW-810	206 x 60 x 24,2	8 x 8
Z.KS.GR.AVQ4405	AVQ / AVL-100	102 x 45 x 15	9 x 9
Z.KS.GR.AVQ5405	AVQ / AVL-125	124,7 x 53 x 15	9 x 9
Z.KS.GR.AVQ6405	AVQ / AVL-160	159,2 x 53 x 18	9 x 9
Z.KS.GR.AVQ8405	AVQ / AVL-200	200 x 56 x 18	9 x 9
Z.KS.GR.HP403T	HP / MP-40	104 x 36 x 11	8 x 8
Z.KS.GR.HP503T	HP / MP-50	130 x 46 x 15	8 x 8
Z.KS.GR.HP603T	HP / MP-60	154 x 54 x 17	8 x 8
Z.KS.GR.HP803T	HP / MP-80	206 x 100 x 30	8 x 8
Z.KS.GR.AVC6405	AVC / AVM-160	160 x 58 x 15	8 x 8
Z.KS.GR.AVC8405	AVC / AVM-200	200 x 63 x 18	8 x 8
Z.KS.GR.TLD4403	TLD-40	102 x 38 x 15	9 x 9
Z.KS.GR.AMC409T	AMC-40	102 x 40 x 21	9 x 9

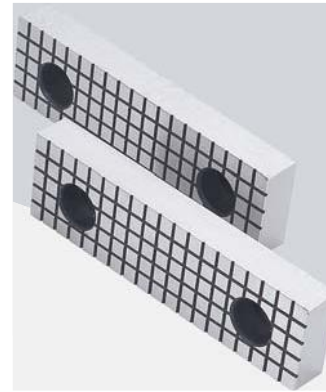

## Niederzugbacken (Paar)

Hold down jaws (Pair)

Mors d'emboutissage (Paire)

Bestell-Nr. Order no. Référence	Ausführung Version Type	Größe-A Size-A Type-A	Größe-B Size-B Type-A
Z.KS.NZ.HP403DA	HP-40	104 x 36 x 12	104 x 36 x 18
Z.KS.NZ.HP503DA	HP / MP-50	130 x 46 x 15,12	130 x 46 x 21
Z.KS.NZ.HP603DA	HP / MP-60	154 x 54 x 17,99	154 x 54 x 21,5
Z.KS.NZ.HP803DA	HP / MP-80	206 x 62 x 21	206 x 62 x 25

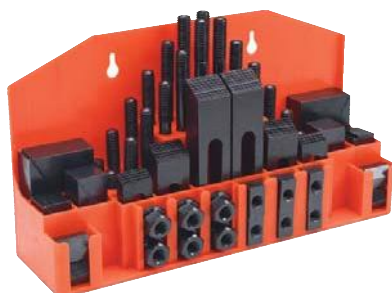

### Weiteres Zubehör auf Anfrage

Further accessories on request

Autres accessoires sur demande



## T-Nuten (T-Nutensteine)

T-Nuts

Tasseaux

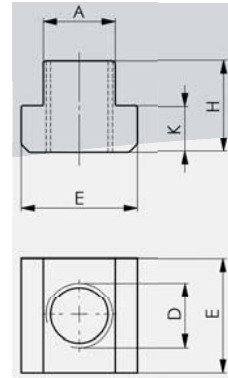
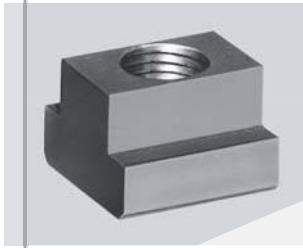

Bestell-Nr. Order no. Référence	Ausführung Version Type	A	E	H	K
Z.KS.80010	M6x8	7,7	13	10	6
Z.KS.80028	M8x10	9,7	15	12	6
Z.KS.80036	M10x12	11,7	18	14	7
Z.KS.800366	M10x16	15,7	25	18	9
Z.KS.81265	M10x18	17,7	28	20	10
Z.KS.80176	M14x18	17,7	28	20	10
Z.KS.80077	M18x20	19,7	32	24	12
Z.KS.80242	M18x22	21,7	35	28	14
Z.KS.80093	M22x24	23,7	40	32	16

## Scheiben DIN 6340

Plain washers DIN 6340

Joints DIN 6340

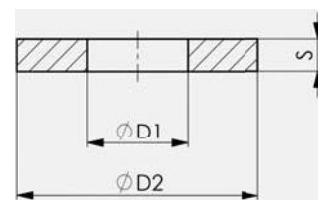

Bestell-Nr. Order no. Référence	Ausführung Version Type	D1	D2	S
Z.KS.82818	M6	6,4	17	2
Z.KS.82826	M8	8,4	23	4
Z.KS.82834	M10	10,5	28	4
Z.KS.82859	M14	15	40	5
Z.KS.82875	M18	19	45	6
Z.KS.82891	M22	23	50	8

## Stiftschrauben DIN 6379

Studs DIN 6379

Boulon fileté DIN 6379

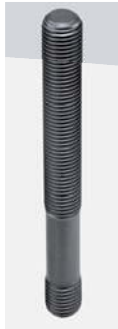

Bestell-Nr. Order no. Référence	Ausführung Version Type	B1	B2
Z.KS.84780	M6x50	9	30
Z.KS.81257	M8x40	11	20
Z.KS.81299	M10x50	13	25
Z.KS.84830	M10x80	13	50
Z.KS.81372	M14x63	17	32
Z.KS.84954	M18x125	23	75
Z.KS.86561	M18x160	23	100
Z.KS.81539	M22x160	31	100

## Sechskantmuttern DIN 6330B

Fixture nuts DIN 6330B

Écrou hexagonal DIN 6330B

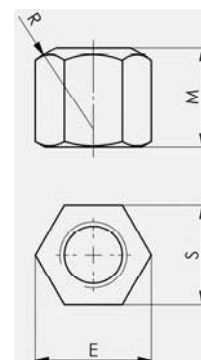

Bestell-Nr. Order no. Référence	Ausführung Version Type	E	M	R	S
Z.KS.82362	M6	11,05	9	9	10
Z.KS.82370	M8	14,40	12	12	13
Z.KS.82354	M10	17,80	15	15	16
Z.KS.82321	M14	23,40	21	20	21
Z.KS.82420	M18	30,10	27	24	27
Z.KS.82339	M22	37,70	33	30	34